

9XTend™ OEM RF Module

9XTend OEM RF Module
Module Operation
Module Configuration
RF Communication Modes
Appendices



Product Manual [v1.2.4](#)

For MaxStream OEM RF Module part numbers that begin with: XT09-R..., XT09-M...

1 Watt Transmit Power, 256-bit AES Encryption



355 South 520 West, Suite 180
Lindon, UT 84042
Phone: (801) 765-9885
Fax: (801) 765-9895

rf-xperts@maxstream.net
www.maxstream.net

M100115
2005.08.02

© 2005 MaxStream, Inc. All rights reserved

No part of the contents of this manual may be transmitted or reproduced in any form or by any means without the written permission of MaxStream, Inc.

XTend™ is a trademark of MaxStream, Inc.

AES Encryption Source Code

© 2005, Dr Brian Gladman, Worcester, UK. All rights reserved.

Conditions:

- Distributions of AES source code include the above copyright notice, this list of conditions and disclaimer.
- Distributions in binary form include the above copyright notice, this list of conditions and disclaimer in the documentation and/or other associated materials.
- The copyright holder's name is not used to endorse products built using this software without specific written permission.

Alternatively, provided that this notice is retained in full, this product may be distributed under the terms of the GNU General Public License (GPL), in which case the provisions of the GPL apply INSTEAD OF those given above.

Disclaimer - This AES software is provided 'as is' with no explicit or implied warranties in respect of its properties, including, but not limited to, correctness and/or fitness for purpose.

Technical Support:

Phone: (801) 765-9885

Live Chat: www.maxstream.net

E-Mail: rf-xperts@maxstream.net

Contents

1. 9XTend™ OEM RF Module	4	Appendix A: Agency Certifications	42
1.1. Features	4	FCC Certification	42
1.1.1. Worldwide Acceptance	4	Labeling Requirements	42
1.2. Specifications	5	FCC Notices	42
1.3. Pin Signals	6	FCC-Approved Antennas (900 MHz)	44
1.4. Electrical Characteristics	7	IC (Industry Canada) Certification	46
1.4.1. Timing Specifications	7	Appendix B: Development Guide	47
1.5. Mechanical Drawings	8	XTend Development Kit Contents	47
2. Module Operation	9	Interfacing Hardware	47
2.1. Serial Communications	9	MaxStream RS-232/485 Interface Board	48
2.1.1. UART-Interfaced Data Flow	9	4.4.2. Adapters	50
2.1.2. Serial Data	9	4.4.3. Antennas	51
2.1.3. Flow Control	10	Interfacing Protocols	52
2.2. Modes of Operation	11	RS-232 Operation	52
2.2.1. Idle Mode	11	RS-485 (2-wire) Operation	54
2.2.2. Transmit Mode	11	RS-485 (4-wire) & RS-422 Operation	55
2.2.3. Receive Mode	13	X-CTU Software	57
2.2.4. Shutdown Mode	13	Appendix C: Additional Information	58
2.2.5. Sleep Mode	14	1-Year Warranty	58
2.2.6. Command Mode	15	Ordering Information	58
3. Module Configuration	17	Contact MaxStream	59
3.1. Hands-on Programming Examples	17		
3.1.1. AT Command Example	17		
3.1.2. Binary Command Example	17		
3.2. Command Reference	18		
3.3. Command Descriptions	19		
4. RF Communication Modes	37		
4.1. Addressing Options	37		
4.2. Streaming Mode	38		
4.2.1. Streaming Mode Connection Sequence	38		
4.3. Acknowledged Mode	39		
4.3.1. Acknowledged Mode Connection Sequence	39		
4.4. Multi-Transmit Mode	41		
4.4.1. Multi-Transmit Mode Connection Sequence	41		

1. 9XTend™ OEM RF Module

The XTend OEM RF Module is MaxStream’s longest range drop-in wireless solution. The module transfers a standard asynchronous serial data stream between two or more modules and sustains throughput data rates up to 115,200 bps.



1.1. Features

Long Range	Easy-to-Use
<p>1 Watt Power Output (1 mW – 1 W, selectable)</p> <p>Range (@ 9600 baud):</p> <ul style="list-style-type: none"> Indoor/Urban: up to 3000’ (900 m) Outdoor line-of-sight: up to 14 miles (22 km) w/ dipole antenna Outdoor line-of-sight: up to 40 miles (64 km) w/ high gain antenna <p>Range (@ 115200 baud):</p> <ul style="list-style-type: none"> Indoor/Urban: up to 1500’ (450 m) Outdoor line-of-sight: up to 7 miles (11 km) w/ dipole antenna Outdoor line-of-sight: up to 20 miles (32 km) w/ high gain antenna <p>Receiver Sensitivity: -110 dBm (@ 9600 baud), -100 dBm (@ 115200 baud)</p>	<p>2.8 to 5.5 V power supply</p> <p>Continuous RF data stream up to 115.2 kbps</p> <p>No configuration required</p> <p>Advanced configurations available through standard AT Commands</p> <p>X-CTU Software for testing and configuration</p> <p>Transparent Operation (Wireless links replace serial wires)</p> <p>Portable (small form-factor easily designed into a wide range of data radio systems)</p> <p>Software-selectable I/O interfacing rates</p> <p>MODBUS, $\overline{\text{CTS}}$, $\overline{\text{RTS}}$, $\overline{\text{DCD}}$, $\overline{\text{DTR}}$ (& more) I/O Support</p> <p>Support for multiple data formats (parity, start and stop bits, etc.)</p> <p>XII™ Interference Immunity</p> <p>Power-saving Shutdown & Sleep Modes (< 1µA)</p>
<p>Advanced Networking & Security</p> <p>True Peer-to-Peer (no “master” required), Point-to-Point, Point-to-Multipoint & Multidrop</p> <p>Retries and Acknowledgements</p> <p>10 hopping channels, each with over 65,000 network addresses available</p> <p>FHSS (Frequency Hopping Spread Spectrum)</p> <p>256-bit AES Encryption (Refer to KY Command [p25])</p>	<p>Free & Unlimited Technical Support</p>

1.1.1. Worldwide Acceptance

FCC Approved (USA) [Refer to Appendix A for FCC Requirements]
Systems that contain XTend Modules inherit MaxStream’s FCC Certification

IC Approved (Canada)

ISM (Industrial, Scientific & Medical) license-free 902-928 MHz frequency band

Manufactured under **ISO 9001:2000 registered standards**



1.2. Specifications

Table 1.1. XTend OEM RF Module

XTend 900 MHz OEM RF Module Specifications			
Performance			
Transmit Power Output (software selectable using PL command)	1 mW - 1 W		
Indoor/Urban Range	Up to 3000' (900 m)		
Outdoor RF line-of-sight Range	Up to 14 miles (22 km) w/ dipole antenna Up to 40 miles (64 km) w/ high-gain antenna		
Interface Data Rate (software selectable using BD command)	1200 – 230400 bps		
Throughput Data Rate (software selectable using BR command)	9,600 bps	115,200 bps	
RF Data Rate	10,000 bps	125,000 bps	
Receiver Sensitivity	-110 dBm	-100 dBm	
Power Requirements			
Receive Current	80 mA		
Shutdown Mode Power Down	< 1 μ A		
Pin Sleep Power Down	147 μ A		
Idle Currents	16 sec cyclic sleep (SM=8)	0.3 - 0.8 mA	
	8 sec cyclic sleep (SM=7)	0.4 - 1.4 mA	
	4 sec cyclic sleep (SM=6)	0.6 - 2.6 mA	
	2 sec cyclic sleep (SM=5)	0.9 - 4.8 mA	
	1 sec cyclic sleep (SM=4)	1.6 - 8.7 mA	
General			
Frequency	902-928 MHz		
Spread Spectrum	FHSS (Frequency Hopping Spread Spectrum)		
Modulation	FSK (Frequency Shift Keying)		
Supported Network Topologies	Peer-to-Peer ("Master/Slave" relationship not required), Point-to-Point, Point-to-Multipoint & Multidrop		
Channel Capacity	10 hop sequences share 50 frequencies		
Encryption	256-bit AES Encryption – Refer to the KY Command [p25] to implement		
Physical Properties			
Module Board Size	1.44" x 2.38" x 0.20" (3.65 cm x 6.05 cm x 0.51 cm)		
Weight	0.64 oz (18 g)		
Connector	20-pin		
Operating Temperature	-40 to 85° C (industrial)		
Antenna			
Connector Options	RPSMA (Reverse-polarity SMA) or MMCX		
Impedance	50 ohms unbalanced		
Certifications (partial list)			
FCC Part 15.247	OUR-9XTEND		
Industry Canada (IC)	4214A-9XTEND		

Table 1.2. XTend OEM RF Module Specifications – Relative to user-selected TX Power Output

Power Requirements (Supply voltage and TX currents relative to each TX Power Output option)					
Transmit Power Output	1 mW	10 mW	100 mW	500 mW **	1 W *
Supply Voltage	2.8 – 5.5 VDC			3.0 – 5.5 VDC	4.75 – 5.5 VDC
Transmit Current (5 V) typical	110 mA	140 mA	270 mA	500 mA	730 mA
Transmit Current (3.3 V) typical	90 mA	110 mA	260 mA	600 mA	**

* If the supply voltage for a given power setting is lower than the minimum supply voltage requirement (as shown in Table 1.2), the TX Power Output will decrease to the highest power level setting given the current supply voltage.

** 1W Power Output is not supported when using a 3.3 supply voltage.

1.3. Pin Signals

Figure 1.1. XTend OEM RF Module Pin Numbers

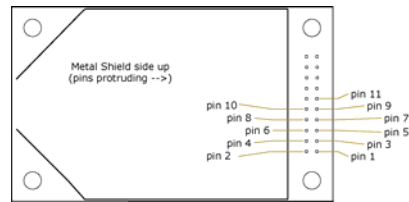

Table 1.3. Pin Signal Descriptions

(Low-asserted signals distinguished with a horizontal line over signal name.)

Pin Number	Mnemonic	I/O	High Impedance during Shutdown	Must Connect	Function
1	GND	-	-	yes	Ground
2	VCC	I	-	yes	Power: 2.8 – 5.5 VDC
3	GPO2 / RX LED	O	yes	-	General Purpose Output 2: <Default (CD=2)> Pin is driven low. Refer to the CD Command [p21] for other configuration options. RX LED: Pin is driven high during RF data reception; otherwise, the pin is driven low. Refer to the CD Command [p21] to enable.
4	<u>TX</u> .PWR	O	yes	-	Transmit Power: Pin pulses low during RF transmission; otherwise, the pin is driven high to indicate power is on and the module is not in Sleep or Shutdown Mode.
5	DI	I	yes	yes	Data In: Serial data entering the module (from the UART host). Refer to the Serial Communications [p9] section for more information.
6	DO	O	yes	-	Data Out: Serial Data exiting the module (to the UART host). Refer to the Serial Communications [p9] section for more information.
7	<u>SHDN</u>	I	no	yes	Shutdown: Pin is driven high during operation and low during Shutdown. Shutdown enables the lowest power mode (< 1 μ A) available to the module. Refer to the Shutdown Mode [p13] section for more information.
8	GPI2 / SLEEP	I	yes	-	General Purpose Input 2: reserved for future use SLEEP: By default, SLEEP is not used. To configure this pin to enable Sleep Modes, refer to the Sleep Mode [p14], SM Command [p32] & PW Command [p28] sections.
9	GPO1 / <u>CTS</u> / RS-485 TX EN	O	yes	-	General Purpose Output 1: reserved for future use CTS (Clear-to-Send): <Default (CS=0)> When pin is driven low, the UART host is permitted to send serial data to the module. Refer to the Serial Communications [p9] & CS Command [p21] sections for more information. RS-485 Transmit Enable: To configure this pin to enable RS-485 half and full duplex communications. Refer to the Serial Communications [p9] & CS Command [p21] sections.
10	GPI1 / <u>RTS</u> / CMD	I	yes	-	General Purpose Input 1: reserved for future use RTS (Request-to-Send): By default, <u>RTS</u> is not used. To configure this pin to regulate the flow of serial data exiting the module, refer to the Serial Communications [p9] & RT Command [p31] sections. CMD (Command): By default, CMD is not used. To configure this pin to enable binary command programming, refer to the Binary Commands [p16] & RT Command [p31] sections.
11	<u>CONFIG</u> / RSSI	I* O*	no no	- -	Configuration: Pin can be used as a backup method for entering Command Mode during power-up. Refer to the Command Mode [p15] section for more information. Receive Signal Strength Indicator: By default, pin is used as an RSSI PWM output after at the conclusion of the power-up sequence. Refer to the RP Command [p30] for more information.
12-20					reserved / do not connect

* Module has 10K Ω internal pull-up resistor

Note: When integrating the XTend Module with a Host PC Board, all lines that are not used should be left disconnected (floating).

1.4. Electrical Characteristics

Figure 1.2. System Block Diagram
Basic wireless link between hosts

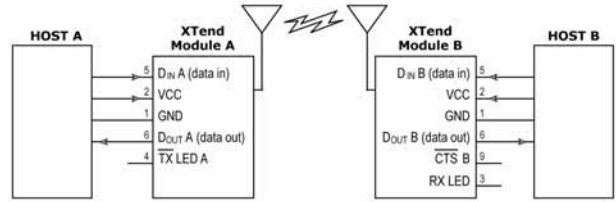

The data flow sequence is initiated when the first byte of data is received in the DI Buffer of the transmitting module (XTend Module A). As long as XTend Module A is not already receiving RF data, data in the DI Buffer is packetized then transmitted over-the-air to XTend Module B.

1.4.1. Timing Specifications

Figure 1.3. Timing Specifications (“A” and “B” refer to Figure 1.2)

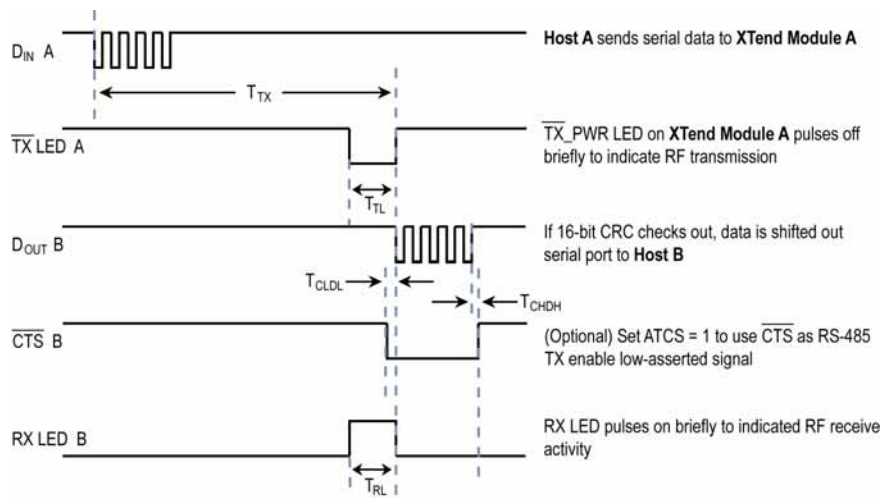

Table 1.4. AC Characteristics (Symbols correspond with Figure 1.2 and Figure 1.3, ATSY Parameter = 0)

Symbol	Description	Sleep Mode	115200 Baud Rate	9600 Baud Rate
T _{TX}	Latency from the time data is transmitted until it is received.	SM = 0 (No sleep)	9.4 msec	94 msec
		SM = 8	16 sec	16 sec
		SM = 7	8 sec	8 sec
		SM = 6	4 sec	4 sec
		SM = 5	2 sec	2 sec
		SM = 4	1 sec	1 sec
T _{TL}	Time that TX_PWR pin (pin 4) is driven low	--	2.45 msec	29.6 msec
T _{RL}	Time that RX LED (pin 3) is driven high	--	2.26 msec	27.2 msec
T _{CLDL}	Time starting when CTS goes low until the first bit appears on D _{OUT}	--	44 μsec	75 μsec
T _{CHDH}	Time after last bit of data until CTS goes high	--	7 μsec	7 μsec

Table 1.5. DC Characteristics (V_{CC} = 2.8 – 5.5 VDC)

Symbol	Parameter	Condition
V _{OL}	Output Low Voltage	V _{OL} = 0.33V (I _O = 6 mA)
V _{OH}	Output High Voltage	V _{OH} = V _{SUPPLY} - 0.7V (-I _O = 6 mA)

Figure 1.4. Input Thresholds vs. Supply Voltage

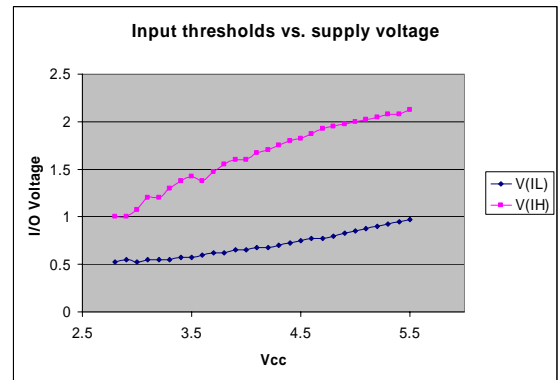

1.5. Mechanical Drawings

Figure 1.5. XTend Module Mechanical Drawings (with RPSMA antenna connector)

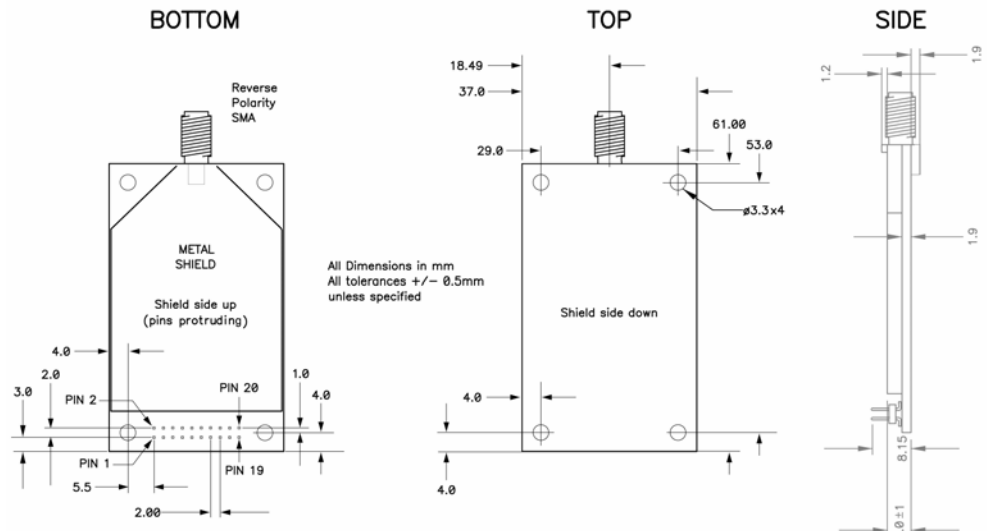
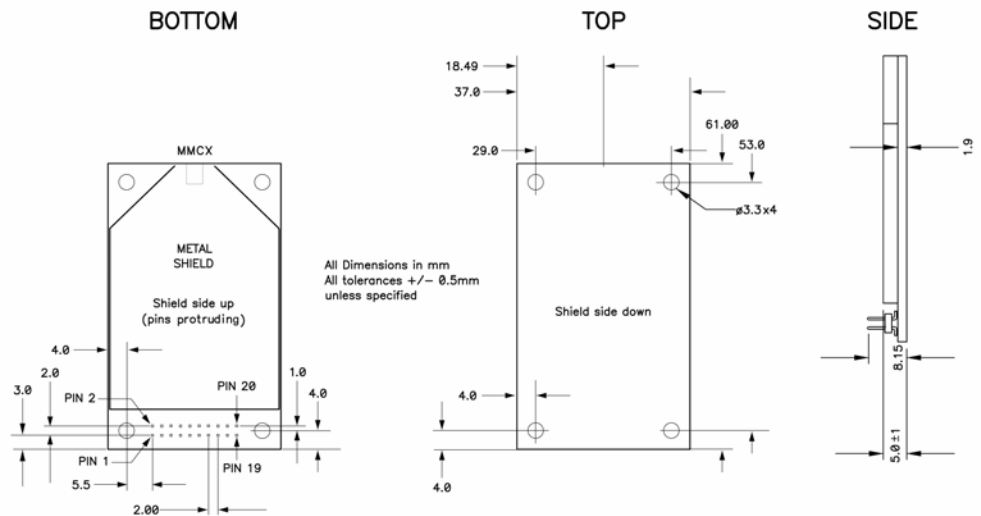

Figure 1.6. XTend Module Mechanical Drawings (with MMCX antenna connector)



2. Module Operation

⚠ WARNING: When operating at 1 Watt power output, observe a minimum separation distance of 2' (0.6 m) between modules. Transmitting in close proximity of other modules can damage module front ends.

2.1. Serial Communications

The XTend OEM RF Module interfaces to a host device through a TTL-level asynchronous serial port. Through its serial port, the module can communicate with any UART voltage compatible device or through a level translator to any RS-232/485/422 device.

2.1.1. UART-Interfaced Data Flow

Devices that have a UART interface can connect directly through the pins of the XTend Module as is shown in the figure below.

Figure 2.1. System Data Flow Diagram in a UART-interfaced environment

(Low-asserted signals distinguished with horizontal line over signal name.)

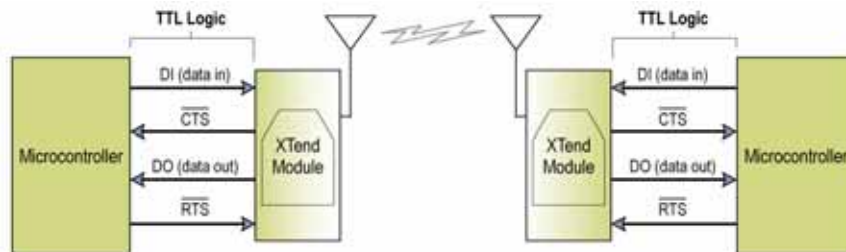

2.1.2. Serial Data

Data enters the XTend Module through the DI pin (pin 5) as an asynchronous serial signal. The signal should idle high when no data is being transmitted.

The UART performs tasks, such as timing and parity checking, that are needed for communications. Serial communication consists of two UARTs configured with compatible parameters (baud rate, parity, start bits, stop bits, data bits) to have successful communication. Each data packet consists of a start bit (low), 8 data bits (least significant bit first) and a stop bit (high). The following figure illustrates the serial bit pattern of data passing through the module.

Figure 2.2. UART data packet 0x1F (decimal number “31”) as transmitted through the XTend Module

Example Data Format is 8-N-1 (bits – parity - # of stop bits)

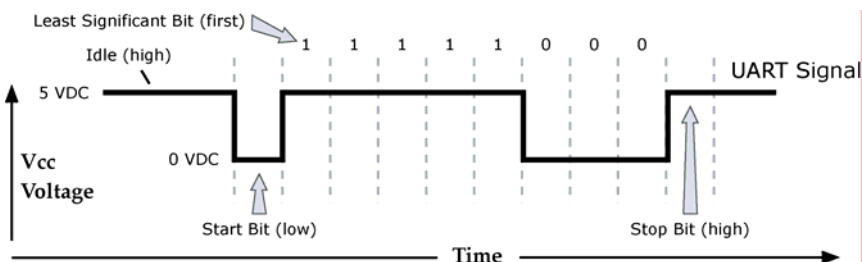

2.1.3. Flow Control

Figure 2.3. Internal Data Flow Diagram (The five most commonly-used pin signals shown.)

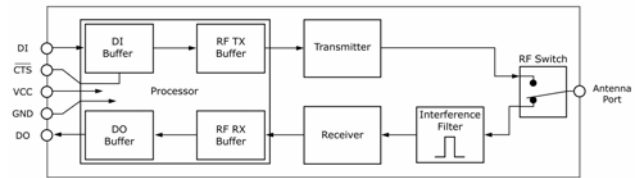

DI (Data In) Buffer and Flow Control

When serial data enters the XTend Module through the DI Pin (pin 5), the data is stored in the DI Buffer until it can be transmitted.

When the RB and RO parameter thresholds are satisfied (refer to Transmit Mode section [p11] for more information), the module attempts to initialize an RF connection. If the module is already receiving RF data, the serial data is stored in the module's DI Buffer. The DI buffer stores at least 2.1 KB. If the DI buffer becomes full, hardware or software flow control must be implemented in order to prevent overflow (loss of data between the host and XTend Module).

How to eliminate the need for flow control:

1. Send messages that are smaller than the DI buffer size. The size of the DI buffer varies according to the packet size (PK parameter) and the parity setting (NB parameter) used.
2. Interface at a lower baud rate (BD parameter) than the RF data rate (BR parameter).

Two cases in which the DI Buffer may become full and possibly overflow:

1. If the serial interface data rate is set higher than the RF data rate of the module, the module will receive data from the host faster than it can transmit the data over-the-air.
2. If the module is receiving a continuous stream of RF data or if the module is monitoring data on a network, any serial data that arrives on the DI pin (pin 5) is placed in the DI Buffer. The data in the DI buffer will be transmitted over-the-air when the module no longer detects RF data in the network.

Hardware Flow Control ($\overline{\text{CTS}}$). When the DI buffer is 17 bytes away from being full; by default, the module de-asserts (high) $\overline{\text{CTS}}$ to signal to the host device to stop sending data [refer to FT (Flow Control Threshold, p24) and CS (GPO1 Configuration, p21) Commands.]. $\overline{\text{CTS}}$ is re-asserted after the DI Buffer has 34 bytes of memory available.

Software Flow Control (XON). XON/XOFF software flow control can be enabled using the FL (Software Flow Control) Command [p23]. This option only works with ASCII data.

DO (Data Out) Buffer & Flow Control

When RF data is received, the data enters the DO buffer and is sent out the serial port to a host device. Once the DO Buffer reaches capacity, any additional incoming RF data is lost. The DO buffer stores at least 2.1 KB.

Two cases in which the DO Buffer may become full and possibly overflow:

1. If the RF data rate is set higher than the interface data rate of the module, the module will receive data from the transmitting module faster than it can send the data to the host.
2. If the host does not allow the module to transmit data out from the DO buffer because of being held off by hardware or software flow control.

Hardware Flow Control ($\overline{\text{RTS}}$). If $\overline{\text{RTS}}$ is enabled for flow control (RT Parameter = 2, p31), data will not be sent out the DO Buffer as long as $\overline{\text{RTS}}$ (pin 10) is de-asserted.

Software Flow Control (XOFF). XON/XOFF software flow control can be enabled using the FL (Software Flow Control) Command [p23]. This option only works with ASCII data.

2.2. Modes of Operation

XTend OEM RF Modules operate in six modes.

Figure 2.4. XTend Modes of Operation

Module can only be in one mode at a time.

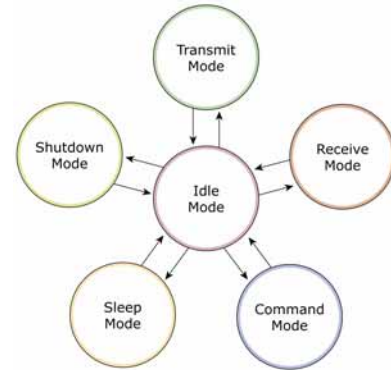

2.2.1. Idle Mode

When not receiving or transmitting data, the module is in Idle Mode. The module uses the same amount of power in Idle Mode as it does in Receive Mode.

The module shifts into the other modes of operation under the following conditions:

- Serial data is received in the DI Buffer (Transmit Mode)
- Valid RF data is received through the antenna (Receive Mode)
- Command Mode Sequence is issued (Command Mode)
- Sleep Mode condition is met (Sleep Mode)
- Shutdown condition is met (Shutdown Mode)

The module automatically transitions back to Idle Mode after responding to these conditions.

2.2.2. Transmit Mode

When the first byte of serial data is received from the UART in the DI buffer, the module attempts to shift to Transmit Mode and initiate an RF connection with other modules. After transmission is complete, the module returns to Idle Mode.

RF transmission begins after either of the following criteria is met:

1. RB bytes have been received by the UART and are pending for RF transmission.
[Refer to the RB (Packetization Threshold) Command, p28]
2. At least one character has been received by the UART and is pending for RF transmission; and RO character times of silence been observed on the UART.
[Refer to the RO (Packetization Timeout) Command, p29]

Figure 2.5. Transmit Mode Data Flow

The character timeout trigger can be disabled by setting RO to zero. In this case, transmission will not begin until RB bytes have been received and are pending for RF transmission. The RB parameter may be set to any value between 1 and the RF packet size (PK (Max RF Packet Size, p27), inclusive). Note that transition to Transmit Mode cannot take place during RF reception; the RF reception must complete before the radio can transition into Transmit Mode.

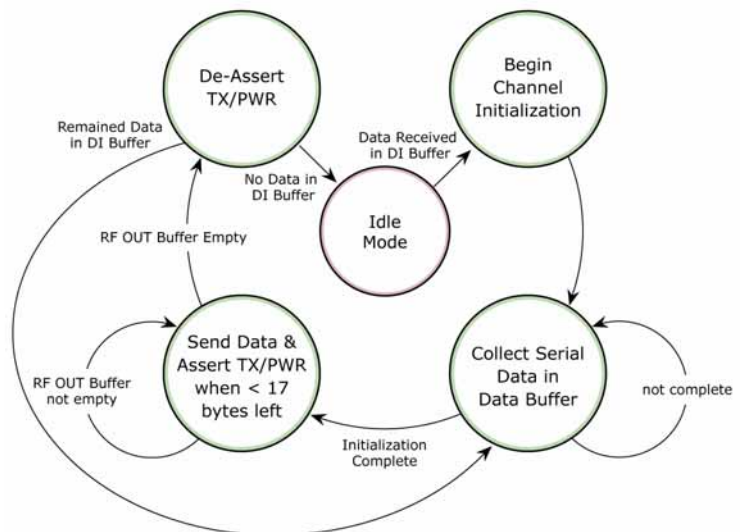

If RB or RO conditions are met, the module initializes a communications channel. Serial data in the DI buffer is grouped into RF packets (up to 2048 bytes in each packet, refer to PK Command), converted to RF data and is transmitted over-the-air until the DI buffer is empty.

Channel initialization is the process of sending an RF initializer that synchronizes receiving modules with the transmitting module. During channel initialization, incoming serial data accumulates in the DI buffer.

RF data, which includes the payload data, follows the RF initializer. The payload includes up to the maximum packet size (PK Command) bytes. As the TX module nears the end of the transmission, it inspects the DI buffer to see if more data exists to be transmitted. This could be the case if more than PK bytes were originally pending in the DI buffer or if more bytes arrived from the UART after the transmission began. If more data is pending, the transmitting module assembles a subsequent packet for transmission.

Refer to the RF Communication Modes [p37] section to view state diagrams that illustrate channel initialization and the sequence of events that follow.

RF Packet

Figure 2.6. RF Packet Components

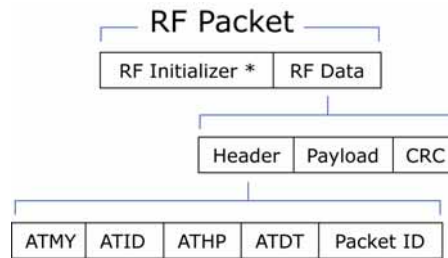

* When streaming multiple RF packets, the RF Initializer is only sent in front of the first packet.

RF Initializer

An RF initializer is sent each time a new connection sequence begins. The RF initializer contains channel information that notifies receiving modules of information such as the hopping pattern used by the transmitting module. The first transmission always sends an RF initializer.

An RF initializer can be of various lengths depending on the amount of time determined to be required to prepare a receiving module. For example, a wake-up initializer is a type of RF initializer used to wake remote modules from Sleep Mode (Refer to the FH, LH, HT and SM Commands for more information). The length of the wake-up initializer should be longer than the length of time remote modules are in cyclic sleep.

Header

The header contains network addressing information that filters incoming RF data. The receiving module checks for matching a Hopping Channel, VID and Destination Address. Data that does not pass through all three network filter layers is discarded.

Figure 2.7. Network Layers Contained in the Header

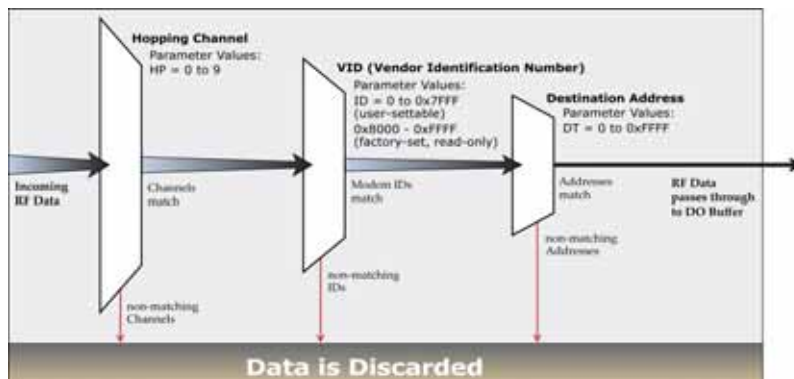

CRC (Cyclic Redundancy Check)

To verify data integrity and provide built-in error checking, a 16-bit CRC (Cyclic Redundancy Check) is computed for the transmitted data and attached to the end of each RF packet. On the receiving end, the receiving module computes the CRC on all incoming RF data. Received data that has an invalid CRC is discarded [See Receive Mode section, next page].

2.2.3. Receive Mode

If a module detects RF data while operating in Idle Mode, the module transitions into Receive Mode to start receiving RF packets. Once a packet is received, the module checks the CRC (cyclic redundancy check) to ensure that the data was transmitted without error. If the CRC data bits on the incoming packet are invalid, the packet is discarded. If the CRC is valid, the packet proceeds to the DO Buffer.

Figure 2.8. Receive Mode Data Flow

* Refer to the Addressing Options [p37] section of the RF Communication Options section for more information about address recognition.

The module returns to Idle Mode when valid RF data is no longer detected or after an error is detected in the received RF data. If serial data is stored in the DI buffer while the module is in Receive Mode, the serial data will be transmitted after the module is finished receiving data and returns to Idle Mode.

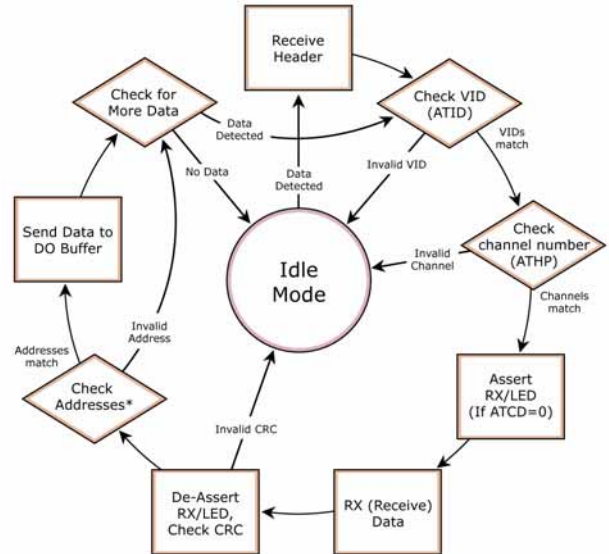

2.2.4. Shutdown Mode

Hardware Sleep

For applications where power consumption must be kept to a minimum during idle periods, Shutdown Mode offers the lowest power mode available to the module.

When the $\overline{\text{SHDN}}$ pin (pin 7) is driven low, the module is forced into shutdown mode. Any communication in progress (transmit or receive) will be halted and any buffered data will be lost. For any other mode of operation, $\overline{\text{SHDN}}$ must be driven or pulled high. While in shutdown mode, the module’s VCC pin draws less than 1 μA .

Immediately after the $\overline{\text{SHDN}}$ pin changes state from low to high, the module resets. After reset, there is a delay that must be observed. See reset section for the delay time.

While $\overline{\text{SHDN}}$ pin is driven low, the following pins are set to high impedance by the module: DCD, TX_PWR, RX LED, DO and $\overline{\text{CTS}}$ (See pin signal descriptions, p6). The $\overline{\text{SHDN}}$ line (also used for RSSI indication) is driven low during shutdown.

The following input pins may continue to be driven by external circuitry when in shutdown mode: PIN_PWR_DWN, $\overline{\text{RTS}}$, DI and $\overline{\text{SHDN}}$.

Note: Because the DO pin also goes high impedance, if the XTend Module is connected to a processor, the UART receive pin could be floating. A weak pull-up should be placed between the module and the microcontroller so that data isn’t interpreted as being transmitted to the microprocessor.

2.2.5. Sleep Mode

Software Sleep

Sleep Modes enable the XTend Module to operate at minimal power consumption when not in use. Three Sleep Mode options are available:

- **Pin Sleep** (Host Controlled)
- **Serial Port Sleep** (Wake on Serial Port activity)
- **Cyclic Sleep** (Wake on RF activity)

For the module to transition into Sleep Mode, the module must have a non-zero SM (Sleep Mode) Parameter and one of the following must occur:

1. The module is idle (no data transmission or reception) for a user-defined period of time [See ST (Time before Sleep) Command, p34].
2. SLEEP pin (pin 8) is asserted (only for Pin Sleep option).

In Sleep Mode, the module will not transmit or receive data until the module first transitions to Idle Mode. All Sleep Modes are enabled and disabled using SM Command. Transitions into and out of Sleep Modes are triggered by various mechanisms as shown in the table below.

Table 2.1. Summary of Sleep Mode Configurations

Sleep Mode Setting	Transition into Sleep Mode	Transition out of Sleep Mode	Related Commands	Typical Power Consumption
Pin Sleep (SM = 1)	A microcontroller can shut down and wake modules by asserting (high) SLEEP pin (pin 8). Note: The module will complete a transmission or reception before activating Pin Sleep.	De-assert (low) SLEEP pin (pin 8).	SM	147 μ A
Serial Port Sleep (SM = 2)	Automatic transition to Sleep Mode occurs after a user-defined period of inactivity (no transmitting or receiving of data). The period of activity is defined using the ST (Time before Sleep) Command.	When serial byte is received on the DI pin (pin 5).	SM, ST	10 mA
Cyclic Sleep (SM = 4-8)	Automatic transition to Sleep Mode occurs in cycles as defined by the SM (Sleep Mode) Command. Note: The cyclic sleep time interval must be shorter than the "Wake-up Initializer Timer" (set by LH Command).	After the cyclic sleep time interval elapses. Note: Module can be forced into Idle Mode if PW (Pin Wake-up) Command is issued.	HT, LH, PW, SM, ST	1.6 mA (when sleeping, SM=4, 1 sec, @120,000 baud)

For more information about Sleep Modes, refer to the individual commands listed in "Related Commands" column of the table. SM Command is the best starting point for implementing Sleep Mode configurations.

Refer to the Hardware Sleep entry of the Shutdown Mode section [previous page] to enable the module's lowest power-consuming state (**1 μ A power down current**).

2.2.6. Command Mode

To set or read module parameters, the module must first enter "Command Mode" (state in which incoming characters are interpreted as commands). Two command types are available for use:

- AT Commands
- Binary Commands

For modified parameter values to persist in the module registry, changes must be saved to non-volatile memory using WR (Write) Command. Otherwise, parameters are restored to previously saved values when the module is powered off and then on again.

AT Command Mode

To Enter AT Command Mode:

1. Send the 3-character command sequence "+++" and observe guard times before and after the command characters. [See "Default AT Command Mode Sequence" below.] The "Terminal" tab (or other serial communications software) of the X-CTU Software can be used to enter the sequence.
[OR]
2. Assert (low) the $\overline{\text{CONFIG}}$ pin and turn the power going to the module off and back on (or pulse the $\overline{\text{SHDN}}$ pin).
[If the module is mounted to a MaxStream XTIB-R Interface Board, press the configuration switch down for 2 seconds.]

Default AT Command Mode Sequence (for transition to AT Command Mode):

- No characters sent for one second [refer to the BT (Guard Time Before) Command]
- Input three plus characters ("+++") within one second [refer to the CC (Command Sequence Character) Command.]
- No characters sent for one second [refer to the AT (Guard Time After) Command.]

To Send AT Commands:

Send AT commands and parameters using the syntax shown below:

Figure 2.9. Syntax for sending AT Commands

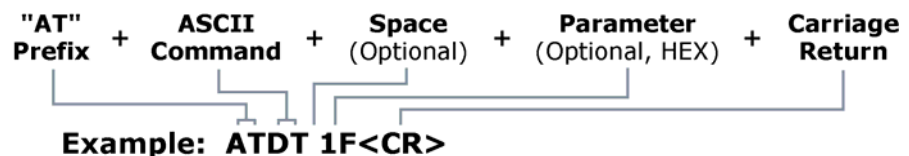

NOTE: To read a parameter value stored in a register, leave the parameter field blank.

The preceding example would change the module Destination Address to "1F". To store the new value to non-volatile (long term) memory, subsequently send the Write (ATWR) Command before powering off the module.

To Exit AT Command Mode:

1. Send ATCN (Exit Command Mode) Command.
[OR]
2. If no valid AT Commands are received within the time specified by CT (Command Mode Timeout) Command, the Module automatically returns to Idle Mode.

For an example that illustrates programming the module using AT Commands, refer to the "Module Configuration" chapter [p17].

Binary Command Mode

Sending and receiving parameter values using binary commands is the fastest way to change operating parameters of the module. Binary commands are used most often to sample signal strength (DB parameter) and/or error counts; or to change module addresses and channels for polling systems when a quick response is necessary. Since the sending and receiving of parameter values takes place through the same serial data path as 'live' data (received RF payload), interference between the two types of data can be a concern.

Common questions about using binary commands:

- What are the implications of asserting CMD while live data is being sent or received?
- After sending serial data, is there a minimum time delay before CMD can be asserted?
- Is a time delay required after CMD is de-asserted before payload data can be sent?
- How does one discern between live data and data received in response to a command?

The CMD pin [pin 10] must be asserted in order to send binary commands to the module. The CMD pin can be asserted to recognize binary commands anytime during the transmission or reception of data. The status of the CMD signal is only checked at the end of the stop bit as the byte is shifted into the serial port. The application does not allow control over when data is received, except by waiting for dead time between bursts of communication.

If the command is sent in the middle of a stream of payload data to be transmitted, the command will essentially be executed in the order it is received. If the module is continuously receiving data, the radio will wait for a break in the received data before executing the command. The $\overline{\text{CTS}}$ signal will frame the response coming from the binary command request [Figure 2.10]

A minimum time delay of 100 μs (after the stop bit of the command byte has been sent) must be observed before the CMD pin can be de-asserted. The command executes after all parameters associated with the command have been sent. If all parameters are not received within 0.5 seconds, the modem returns to Idle Mode.

Note: When parameters are sent, they are two bytes long with the least significant byte sent first. Binary commands that return one parameter byte must be written with two parameter bytes.

Refer to p17 for a binary programming example (DT command example returns two bytes).

Commands can be queried for their current value by sending the command logically ORed (bit-wise) with the value 0x80 (hexadecimal) with CMD asserted. When the binary value is sent (with no parameters), the current value of the command parameter is sent back through the DO pin.

Figure 2.10. Binary Command Write then Read

Signal #4 is CMD (pin 10)
Signal #1 is the DIN (pin 5) signal
Signal #2 is the DOUT (pin 6) signal from the radio
Signal #3 is $\overline{\text{CTS}}$ (pin 9)

In this graph, a value was written to a register and then read out to verify it. While not in the middle of other received data, note that the $\overline{\text{CTS}}$ signal outlines the data response out of the module.

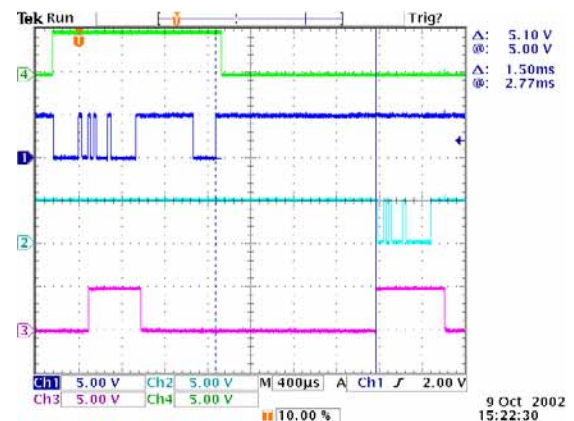

IMPORTANT: In order for the XTend Module to recognize a binary command, the RT (GPIO Configuration) parameter must be set to one. If binary programming is not enabled (RT \neq 1), the module will not recognize that the CMD pin (Pin 10) is asserted and therefore will not recognize the data as binary commands.

3. Module Configuration

3.1. Hands-on Programming Examples

For information about entering and exiting AT and Binary Command Modes, refer to the Command Mode section [p15].

3.1.1. AT Command Example

To Send AT Commands (Using the Terminal tab of MaxStream's X-CTU Software)

Note: Do not send commands to the module during flash programming (when parameters are being written to the module registry). Wait for the "OK" system response that follows the ATWR command before entering the next command or use flow control.

Example: Both of the following examples change the module's destination address to 0x1A0D and save the new address to non-volatile memory. <CR> stands for "Carriage Return".

Method 1 (One line per command)

Send AT Command	System Response
+++	OK <CR> (Enter into Command Mode)
ATDT <Enter>	current destination address <CR>
ATDT1A0D <Enter>	OK <CR> (Change destination address)
ATWR <Enter>	OK <CR> (Write to non-volatile memory)
ATCN <Enter>	OK <CR> (Exit AT Command Mode)

Method 2 (Multiple commands on one line)

Send AT Command	System Response
+++	OK <CR> (Enter into Command Mode)
ATDT <Enter>	current destination address <CR>
ATDT1A0D,WR <Enter>	OK <CR> (Execute commands)
ATCN <Enter>	OK (Exit AT Command Mode)

Note: When using X-CTU Software to program a module, PC com port settings must match the baud (interface data rate), parity & stop bits parameter values of the module. Use the 'Com Port Setup' section of the "PC Settings" tab to configure PC com port settings to match those of the module.

3.1.2. Binary Command Example

To Send Binary Commands:

Example: Use binary commands to change the XTend Module's destination address to 0x1A0D and save the new address to non-volatile memory.

- RT Command must be set to '1' in AT Command Mode to enable binary programming.
- Assert CMD (Pin 10 is driven high). (Enter Binary Command Mode)
- Send Bytes [parameter bytes must be 2 bytes long]:

00	(Send DT (Destination Address) Command)
0D	(Least significant byte of parameter bytes)
1A	(Most significant byte of parameter bytes)
08	(Send WR (Write) Command)
- De-assert CMD (Pin 10 is driven low) (Exit Binary Command Mode)

Note: \overline{CTS} (pin 9) is high when command is being executed. Hardware flow control must be disabled as \overline{CTS} will hold off parameter bytes.

3.2. Command Reference

Table 3.1. XTend Commands (“d” denotes decimal equivalent)

AT Command	Binary Command	AT Command Name	Parameter Range	Command Category	# Bytes Returned	Factory Default
%V	0x3B (59d)	Board Voltage	0x2CCCCA – 0x5BFFFA [read-only]	Diagnostics	4	-
AM	0x40 (64d)	Auto-set MY	-	Networking & Security	-	-
AT	0x05 (5d)	Guard Time After	2 - (ATST-3) [x 100 msec]	Command Mode Options	2	0x0A (10d)
BD	0x15 (21d)	Baud Rate (Interface Data Rate)	0 - 8	Serial Interfacing	1	3
BR	0x39 (57d)	RF Data Rate	0 - 1	RF Interfacing	1	1
BT	0x04 (4d)	Guard Time Before	0 – 0xFFFF [x 100 msec]	Command Mode Options	2	0x0A (10d)
CC	0x13 (19d)	Command Sequence Character	0x20 - 0x7F	Command Mode Options	1	0x2B [“+”] (43d)
CD	0x28 (40d)	GPO2 Configuration	0 - 2	Serial Interfacing	1	2
CF	-	Number Base	0 - 2	Command Mode Options	1	1
CN	0x09 (9d)	Exit Command Mode	-	Command Mode Options	-	-
CS	0x1F (31d)	GPO1 Configuration	0 - 4	Serial Interfacing	1	0
CT	0x06 (6d)	Command Mode Timeout	2 – 0xFFFF [x 100 ms]	Command Mode Options	2	0xC8 (200d)
DB	0x36 (54d)	Received Signal Strength	0x6E to 0x28 [read-only]	Diagnostics	2	-
DT	0x00 (0d)	Destination Address	0 - 0xFFFF	Networking & Security	2	0
E0	0x0A (10d)	Echo Off	-	Command Mode Options	-	-
E1	0x0B (11d)	Echo On	-	Command Mode Options	-	-
ER	0x0F (15d)	Receive Error Count	0 – 0xFFFF	Diagnostics	2	0
FH	0x0D (13d)	Force Wake-up Initializer	-	Sleep (Low Power)	-	-
FL	0x07 (7d)	Software Flow Control	0 - 1	Serial Interfacing	1	0
FS	0x3E (62d)	Forced Sync Time	1 – 0xFFFF [x 10 msec]	RF Interfacing	2	0
FT	0x24 (36d)	Flow Control Threshold	0 – DI Buffer size (bytes)	Serial Interfacing	2	varies
GD	0x10 (16d)	Receive Good Count	0 – 0xFFFF	Diagnostics	2	0
HP	0x11 (17d)	Hopping Channel	0 - 9	Networking & Security	1	0
HT	0x03 (3d)	Time before Wake-up Initializer	0 – 0xFFFF [x 100 msec]	Sleep (Low Power)	2	0xFFFF (65535d)
HV	-	Hardware Version	0 – 0xFFFF [read-only]	Diagnostics	2	-
ID	0x27 (39d)	Modem VID	0 - 0x7FFF (user-settable) 0x8000 - 0xFFFF (factory-set)	Networking & Security	2	0x3332 (13106d)
KY	0x3C (60d)	AES Encryption Key	0 – (Any other 64-digit hex valid key)	Networking & Security	2	0
LH	0x0C (12d)	Wake-up Initializer Timer	0 – 0xFF [x 100 msec]	Sleep (Low Power)	1	1
MK	0x12 (18d)	Address Mask	0 - 0xFFFF	Networking & Security	2	0xFFFF (65535d)
MT	0x3D (61d)	Multi-Transmit	0 – 0xFF	Networking & Security	1	0
MY	0x2A (42d)	Source Address	0 - 0xFFFF	Networking & Security	2	0xFFFF (65535d)
NB	0x23 (35d)	Parity	0 - 4	Serial Interfacing	1	0
PK	0x29 (41d)	Maximum RF Packet Size	1 – 0x800 [Bytes]	RF Interfacing	2	0x800 (2048d)
PL	0x3A (58d)	TX Power Level	0 - 4	RF Interfacing	1	4 [1 Watt]
PW	0x1D (29d)	Pin Wake-up	0 - 1	Sleep (Low Power)	1	0
RB	0x20 (32d)	Packetization Threshold	1 - Current value of PK	Serial Interfacing	2	0x800 (2048d)
RC	-	Ambient Power - Single Channel	0 – 0x31 [dBm, read-only]	Diagnostics	1	-
RE	0x0E (14d)	Restore Defaults	-	(Special)	-	-
RM	-	Ambient Power - All Channels	No parameter – 0x7D0	Diagnostics	2	-
RN	0x19 (25d)	Delay Slots	0 – 0xFF (slots)	Networking & Security	1	0
RO	0x21 (33d)	Packetization Timeout	0 – 0xFFFF [x UART character time]	Serial Interfacing	2	3
RP	0x22 (34d)	RSSI PWM Timer	0 – 0xFF [x 100 msec]	Diagnostics	1	0x20 (32d)
RR	0x18 (24d)	Retries	0 – 0xFF	Networking & Security	1	0x0A (10d)
RT	0x16 (22d)	GPI1 Configuration	0 - 2	Serial Interfacing	1	0
SB	0x37 (55d)	Stop Bits	0 - 1	Serial Interfacing	1	0
SH	0x25 (37d)	Serial Number High	0 – 0xFFFF [read-only]	Diagnostics	2	varies
SL	0x26 (38d)	Serial Number Low	0 – 0xFFFF [read-only]	Diagnostics	2	varies
SM	0x01 (1d)	Sleep Mode	0 - 2, 4 - 8; 3 reserved	Sleep (Low Power)	1	0
ST	0x02 (2d)	Time before Sleep	(ATAT+3) – 0x7FFF [x 100 msec]	Sleep (Low Power)	2	0x64 (100d)
TP	0x38 (56d)	Board Temperature	0 – 0x7F [read-only]	Diagnostics	1	-
TR	0x1B (27d)	Delivery Failure Count	0 – 0xFFFF [read-only]	Diagnostics	2	0
TT	0x1A (26d)	Streaming Limit	0 – 0xFFFF [0 = disabled]	Networking & Security	2	0
TX	0x3F (63d)	Transmit Only	0 - 1	RF Interfacing	1	0
VL	-	Firmware Version - verbose	Returns string	Diagnostics	-	-
VR	0x14 (20d)	Firmware Version	0 - 0xFFFF [read-only]	Diagnostics	2	-
WA	-	Active Warning Numbers	Returns string	Diagnostics	-	-
WN	-	Warning Data	Returns string	Diagnostics	-	-
WR	0x08 (8d)	Write	-	(Special)	-	-
WS	-	Sticky Warning Numbers	Returns string	Diagnostics	-	-

* Firmware version in which the command and parameter options were first supported.

3.3. Command Descriptions

Commands in this section are listed alphabetically. Command categories are designated between the "< >" symbols that follow each command title. By default, XTend Modules expect numerical values in hexadecimal since the default value of the CF (Number Base) Parameter is '1'. Hexadecimal values are designated by the "0x" prefix and decimal values by the "d" suffix.

%V (Board Voltage) Command

<Diagnostics> %V Command is used to read the current voltage of the XTend Module circuit board.

Sample Output: 5.02 V (when ATCF = 0)
 5051F (when ATCF = 1) *
 5.02 (when ATCF = 2)

* When CF = 1 (default), a hex integer is shown that is equal to (voltage * 65536d).

AT Command: AT%V

Binary Command: 0x3B (59 decimal)

Parameter Range (read-only):
 0x2CCCA - 0x5BFFA
 (2.80 - 5.75 decimal)

Number of bytes returned: 4

AM (Auto-set MY) Command

<Networking & Security> AM Command is used to automatically set the MY (Source Address) parameter from the factory-set module serial number. The address is formed with bits 29, 28 and 13-0 of the serial number (in that order). The value is displayed as a result of this command.

AT Command: ATAM

Binary Command: 0x40 (64 decimal)

AT (Guard Time After) Command

<Command Mode Options> AT Command is used to set/read the time-of-silence that follows the command sequence character (CC Command). By default, 1 second must elapse before and after the command sequence character.

The default sequence used to enter AT Command Mode is as follows:

- No characters sent for 1 second [BT (Guard Time Before) Command]
- Send three plus characters "+++" [CC (Command Sequence Character) Command]
- No characters sent for 1 second [AT (Guard Time After) Command]

All of the values in this sequence can be adjusted. AT Command is used to adjust the period of silence that follows the command sequence character.

AT Command: ATAT

Binary Command: 0x05 (5 decimal)

Parameter Range: 2 - (ATST-3), up to 0x7FFC
 [x 100 milliseconds]

Default Parameter Value: 0x0A (10 decimal)

Number of bytes returned: 2

Related Commands: BT (Guard Time Before),
 CC (Command Sequence Character)

BD (Baud Rate) Command

<Serial Interfacing> BD Command is used to set/read the UART I/O serial data rate (the rate at which serial data is sent to the module). Newly modified serial data rates do not take effect until the module exits Command Mode [refer to CN (Exit Command Mode) and CT (Command Mode Timeout) Commands].

The RF data rate is not affected by the BD Command.

Note: If the serial data rate is set to exceed the fixed RF data rate of the XTend module, CTS flow control may need to be implemented. Refer to the Pin Signals [p6] and CS (GPO1 Configuration Command [p21] sections for more information.

AT Command: ATBD

Binary Command: 0x15 (21 decimal)

Parameter Range: 0 - 8

Parameter Value	BAUD (bps) Configuration
0	1200
1	2400
2	4800
3	9600
4	19200
5	38400
6	57600
7	115200
8	230400

Default Parameter Value: 3

Number of bytes returned: 1

BR (RF Data Rate) Command

<RF Interfacing> BR Command is used to set/read the RF data rate (rate that RF data is transmitted over-the-air) of the module.

AT Command: ATBR

Binary Command: 0x39 (57 decimal)

Parameter Range: 0 - 1

Parameter Value	BAUD (bps) Configuration
0	9600
1	115200

Default Parameter Value: 1

Number of bytes returned: 1

BT (Guard Time Before) Command

<Command Mode Options> BT Command is used to set/read the time-of-silence that precedes the command sequence character (CC Command) of the AT Command Mode Sequence.

Refer to the CC command to view the default AT Command Sequence.

AT Command: ATBT

Binary Command: 0x04 (4 decimal)

Parameter Range: 0 - 0xFFFF
[x 100 milliseconds]

Default Parameter Value: 0x0A (10 decimal)

Number of bytes returned: 2

Related Commands: AT (Guard Time After), CC (Command Sequence Character)

CC (Command Sequence Character) Command

<Command Mode Options> CC Command is used to set/read the ASCII character used between Guard Times of the AT Command Mode Sequence (BT+ CC + AT). The AT Command Mode Sequence activates AT Command Mode (from Idle Mode).

The default sequence used to enter AT Command Mode is as follows:

- No characters sent for 1 second [BT (Guard Time Before) Command]
- Send three plus characters “+++” [CC (Command Sequence Character) Command]
- No characters sent for 1 second [AT (Guard Time After) Command]

All of the values in this sequence can be adjusted.

AT Command: ATCC

Binary Command: 0x13 (19 decimal)

Parameter Range: 0x20 - 0x7F

Default Parameter Value: 0x2B (ASCII “+” sign)

Number of bytes returned: 1

Related Commands: AT (Guard Time After), BT (Guard Time Before)

CD (GPO2 Configuration) Command

<Serial Interfacing> CD Command is used to select/read the behavior of the GPO2 line (pin 3).

AT Command: ATCD

Binary Command: 0x28 (40 decimal)

Parameter Range: 0 - 2

Parameter Value	Configuration
0	RX LED
1	Default high
2	Default low

Default Parameter Value: 2

Number of bytes returned: 1

CF (Number Base) Command

<Command Mode Options> CF command is used to set/read command formatting setting.

The following commands are always entered and read in hex, no matter the CF setting:

VR (Firmware Version), HV (Hardware Version), KY (AES Encryption Key).

AT Command: ATCF

Binary Command: 0x1F (31 decimal)

Parameter Range: 0 - 2

Parameter Value	Configuration
0	Commands utilize default number base; decimal commands may output units
1	All commands are forced to unsigned, unit-less hex
2	Commands utilize their default number base; no units are output

Default Parameter Value: 1

Number of bytes returned: 1

CN (Exit Command Mode) Command

<Command Mode Options> CN Command is used to explicitly exit AT Command Mode.

AT Command: ATCN

Binary Command: 0x09 (9 decimal)

CS (GP01 Configuration) Command

<Serial Interfacing> CS Command is used to select the behavior of the GP01 pin (pin 9). This output can provide RS-232 flow control, control the TX enable signal (for RS-485 or RS-422 operations), or set the default level for the I/O line passing function.

By default, GP01 provides RS-232 $\overline{\text{CTS}}$ (Clear-to-Send) flow control.

AT Command: ATCS

Binary Command: 0x1F (31 decimal)

Parameter Range: 0 - 4

Parameter Value	Configuration
0	RS-232 $\overline{\text{CTS}}$ flow control
1	RS-485 TX enable low
2	high
3	RS-485 TX enable high
4	low

Default Parameter Value: 0

Number of bytes returned: 1

Related Commands: RT (GP11 Configuration), TO (GP01 Timeout)

CT (Command Mode Timeout) Command

<Command Mode Options> CT Command is used to set the amount of time before AT Command Mode terminates automatically. After a CT time of inactivity, the modem exits AT Command Mode and returns to Idle Mode. AT Command Mode can also be exited manually by issuing the CN (Exit AT Command Mode) Command.

AT Command: ATCT

Binary Command: 0x06 (6 decimal)

Parameter Range: 2 – 0xFFFF [x 100 ms]

Default Parameter Value: 0xC8 (200d)

Number of bytes returned: 2

Related Command: CN (Exit Command Mode)

DB (Received Signal Strength) Command

<Diagnostics> DB Command is used to read the receive signal strength (in decibels relative to milliWatts) of the last received packet. This parameter is useful in determining range characteristics of XTend Modules under various conditions.

In default mode, this command shows the power level in signed decimal format, with the units (dBm). If CF is set to 1, the magnitude of the value is presented in unsigned hex. If CF is set to 2, the value is presented in decimal, but without the units.

Sample Output:	-88 dBm	(when ATCF = 0)
	58	(when ATCF = 1)
	-88	(when ATCF = 2)

NOTE: If the DB register is read before the modem has received an RF packet, the modem will return a value of 0x8000 (which means an RF packet has not yet been received).

AT Command: ATDB

Binary Command: 0x36 (54 decimal)

Parameter Range (read-only):
0x6E – 0x28
(-110 to -40 Decimal)

Number of bytes returned: 2

Related Command: CN (Exit Command Mode)

DT (Destination Address) Command

<Networking & Security> DT Command is used to set/read the networking address of an XTend Module. XTend Modules uses three network layers –Vendor Identification Number (ATID), Channels (ATHP), and Destination Addresses (ATDT). DT Command assigns an address to a module that enables it to communicate only with other modules having the same addresses. All modules that share the same DT parameter can communicate freely with each other.

Modules in the same network with a different destination address (than that of the transmitter) will listen to all transmissions to stay synchronized, but will not send any of the data out their serial ports.

AT Command: ATDT

Binary Command: 0x00

Parameter Range: 0 – 0xFFFF

Default Parameter Value: 0

Number of bytes returned: 2

Related Commands: HP (Hopping Channel), ID (Modem VID), MK (Address Mask), MY (Source Address)

E0 (Echo Off) Command

<Command Mode Options> E0 Command turns off character echo in AT Command Mode. By default, echo is off.

AT Command: ATE0

Binary Command: 0x0A (10 decimal)

E1 (Echo On) Command

<Command Mode Options> E1 Command turns on the character echo in AT Command Mode. Each typed character will be echoed back to the terminal when ATE1 is active. E0 is the default.

AT Command: ATE1

Binary Command: 0x0B (11 decimal)

ER (Receive Error Count) Command

<Diagnostics> Set/Read the number of receive-errors. The error count records the number of packets partially received then aborted on a reception error. This value returns to 0 after a reset and is not non-volatile (Value does not persist in the module’s memory after a power-up sequence). Once the Receive Error Count reaches its maximum value (up to 0xFFFF), it remains at its maximum count value until the maximum count value is explicitly changed or the module is reset.

The ER parameter is not reset by pin, serial port or cyclic sleep modes.

AT Command: ATER
 Binary Command: 0x0F (15 decimal)
 Parameter Range: 0 - 0xFFFF
 Default Parameter Value: 0
 Number of bytes returned: 2
 Related Commands: GD (Receive Good Count)

FH (Force Wake-up Initializer) Command

<Sleep (Low Power)> FH Command is used to force a Wake-up Initializer to be sent on the next transmission. WR (Write) Command does not need to be issued with FH Command.

Use only with cyclic sleep modes active on remote modules.

AT Command: ATFH
 Binary Command: 0x0D (13 decimal)

FL (Software Flow Control) Command

<Serial Interfacing> FL Command is used to configure software flow control. Hardware flow control is implemented with the XTend Module as the GP01 pin (pin 9, \overline{CTS}), which regulates when serial data can be transferred to the module.

FL Command can be used to allow software flow control to also be enabled. XON character used is 0x11 (17 decimal). XOFF character used is 0x13 (19 decimal).

AT Command: ATFL
 Binary Command: 0x07 (7 decimal)
 Parameter Range: 0 - 1

Parameter Value	Configuration
0	Disable software flow control
1	Enable software flow control

Default Parameter Value: 0
 Number of bytes returned: 1

FS (Forced Synch Time) Command

<RF Interfacing> FS Command only applies to streaming data. Normally, only the first packet of a continuous stream has the full RF initializer. The modules then remain synchronized for subsequent packets of the stream. This parameter can be used to periodically force an RF initializer during such streaming. Any break in UART character reception long enough to drain the DI Buffer (UART receive buffer) and cause a pause in RF data transmission will also cause an RF initializer to be inserted on the next transmission.

AT Command: ATFS
 Binary Command: 0x3E (62 decimal)
 Parameter Range: 0 - 0xFFFF
 [x 10 milliseconds]
 Default Parameter Value: 0
 Number of bytes returned: 2

FT (Flow Control Threshold) Command

<Serial Interfacing> Set/Read the flow control threshold. When FT bytes have accumulated in the DI buffer, \overline{CTS} is de-asserted or the XOFF software flow control character is transmitted.

AT Command: ATFT

Binary Command: 0x24 (36 decimal)

Parameter Range: 0 – (Receive buffer size minus 0x11 bytes)

Default Parameter Value: DO Buffer size minus 0x11 (decimal 17)

Number of bytes returned: 2

GD (Receive Good Count) Command

<Diagnostics> Set/Read the count of good received RF packets. Parameter value is reset to 0 after every reset and is not non-volatile (Value does not persist in the module's memory after a power-up sequence). Once the "Receive Good Count" reaches its maximum value (up to 0xFFFF), it remains at its maximum count value until the maximum count value is manually changed or the module is reset.

AT Command: ATGD

Binary Command: 0x10 (16 decimal)

Parameter Range: 0 – 0xFFFF

Default Parameter Value: 0

Number of bytes returned: 2

Related Commands: ER (Receive Error Count)

The GD parameter is not reset by pin, serial port or cyclic sleep modes.

HP (Hopping Channel) Command

<Networking & Security> HP Command is used to set/read the module's hopping channel number. A channel is one of three layers of addressing available to the XTend Module.

AT Command: ATHP

Binary Command: 0x11 (17 decimal)

Parameter Range: 0 – 9

Default Parameter Value: 0

Number of bytes returned: 1

Related Commands: ID (Modem VID), DT (Destination Address), MK (Address Mask)

In order for modules to communicate with each other, the modules must have the same channel number since each channel uses a different hopping sequence. Different channels can be used to prevent modules in one network from listening to transmissions of another.

HT (Time before Wake-up Initializer) Command

<Sleep (Low Power)> Set/read time of inactivity (no serial or RF data is sent or received) before a wake-up initializer is sent by a TX module. HT should be set shorter than inactivity timeout [ST Command] time of any RX modules operating in Cyclic Sleep (SM=4-8). The wake-up initializer sent by the TX module instructs all RX modules to remain awake to receive RF data.

AT Command: ATHT

Binary Command: 0x03 (3 decimal)

Parameter Range: 0 – 0xFFFF
[x 100 milliseconds]

Default Parameter Value: 0xFFFF (wake-up initializer will not be sent)

Number of bytes returned: 2

Related Commands: LH (Wake-up Initializer Timer), SM (Sleep Mode), ST (Time before Sleep)

From the RX module perspective: After HT time elapses and the inactivity timeout [ST Command] is met, the RX module goes into cyclic sleep. In cyclic sleep, the RX module wakes once per sleep interval [SM Command] to check for a wake-up initializer. When a wake-up initializer is detected, the module stays awake to receive data. The wake-up initializer must be longer than the cyclic sleep interval to ensure that sleeping modules detect incoming data.

When HT time elapses, the TX module knows it needs to send a wake-up Initializer for all RX modules to remain awake and receive the next transmission.

HV (Hardware Version) Command

<Diagnostics> HV Command is used to read the hardware version of the module.

AT Command: ATHV

Parameter Range (read-only): 0 – 0xFFFF

Number of bytes returned: 2

ID (Modem VID) Command

<Networking & Security> ID Command is used to set/read the VID (Vendor Identification Number) of the module. Modules must have matching VIDs in order to communicate.

AT Command: ATID

Binary Command: 0x27 (39 decimal)

Parameter Range:

0 – 0x7FFF (user-settable)

0x8000 – 0xFFFF (factory-set)

Default Parameter Value: 0x3332 (13106d)

Number of bytes returned: 2

KY (AES Encryption Key) Command

<Networking & Security> KY Command is used to set the 256-bit AES (Advanced Encryption Standard) key for encryption/decryption of data. Once set, the key cannot be read out of the module by any means. The entire payload of the packet is encrypted using the key and the CRC is computed across the ciphertext. When encryption is turned on, each packet carries an additional 16 bytes to convey the random CBC Initialization Vector (IV) to the receiver(s).

AT Command: ATKY

Binary Command: 0x3C (60 decimal)

Parameter Range:

0 – (any other 64-digit hex valid key)

Default Parameter Value: 0 (disabled)

Number of bytes returned: 2

Number Base: Always Hexadecimal

A module with the wrong key (or no key) will still receive encrypted data, but the resultant data driven out the serial port will be meaningless. Likewise, a module with a key will still receive unencrypted data sent from a module without a key, but the output will be meaningless.

Because CBC mode is utilized, repetitive data appears different in different transmissions due to the randomly-generated IV.

LH (Wake-up Initializer Timer) Command

<Sleep (Low Power)> LH Command is used to set/read the duration of time for which the wake-up initializer is sent. When receiving modules are put into Cyclic Sleep Mode, they power-down after a period of inactivity [specified by ST (Time before Sleep) Command] and will periodically awaken and listen for transmitted data. In order for the receiving modules to remain awake, they must detect ~35ms of the wake-up initializer.

AT Command: ATLH

Binary Command: 0x0C (12 decimal)

Parameter Range: 0 – 0xFF

[x 100 milliseconds]

Default Parameter Value: 1

Number of bytes returned: 1

Related Commands: HT (Time before Wake-up Initializer), SM (Sleep Mode), ST (Time before Sleep)

LH Command must be used whenever a receiver is operating in Cyclic Sleep Mode. This lengthens the Wake-up Initializer to a specific amount of time (in tenths of a second). The Wake-up Initializer Time must be longer than the cyclic sleep time that is determined by SM (Sleep Mode) Command. If the wake-up initializer time were less than the Cyclic Sleep interval, the connection would be at risk of missing the wake-up initializer transmission.

Refer to Figures 3.1 & 3.2 of the SM Command description to view diagrams of correct and incorrect configurations. The images help visualize the importance that the value of LH be greater than the value of SM.

MK (Address Mask) Command

<Networking & Security> MK Command is used to set/read the "Address Mask". All data packets contain the Destination Address of the transmitting module.

When an RF data packet is received, the transmitter's Destination Address is logically "ANDed" (bitwise) with the Address Mask of the receiver. The resulting value must match the Destination Address or the Address Mask of the receiver for the packet to be received and sent out the module's DO serial port. If the "ANDed" value does not match either the Destination Address or the Address Mask of the receiver, the packet is discarded. (All "0" values are treated as "irrelevant" values and are ignored.)

AT Command: ATMK

Binary Command: 0x12 (18 decimal)

Parameter Range: 0 – 0xFFFF

Default Parameter Value: 0xFFFF (65535d)
Destination address (DT parameter) of the transmitting module must exactly match the destination address of the receiving module.

Number of bytes returned: 2

Related Commands: DT (Destination Address), HP (Hopping Channel), ID (Modem VID), MY (Source Address)

MT (Multi-Transmit) Command

<Networking & Security> MT packets do not request an acknowledgement from the receiving module(s). MT takes precedence over RR, so if both MT and RR are non-zero, then MT+1 packets will be sent, with no ACK requests.

When a receiving module receives a packet with remaining forced retransmissions, it calculates the length of the packet and inhibits transmission for the amount of time required for all retransmissions. Thereafter, a random number of delay slots are inserted between 0 and RN before transmission is allowed from the receiving module(s). This prevents all listening modules from transmitting at once upon conclusion of a multiple transmission event (when RN > 0).

Comment: Actual number of forced transmissions is the parameter value plus one. For example, if MT=1, two transmissions of each packet will be sent.

AT Command: ATMT

Binary Command: 0x3D (61 decimal)

Parameter Range: 0 – 0xFF

Default Parameter Value: 0 (no forced retransmissions)

Number of bytes returned: 1

Related Commands: Networking (DT, MK, MY, RN, TT), Serial Interfacing (BR, PK, RB, RO), RF Interfacing (FS)

MY (Source Address) Command

<Networking & Security> Set/Read the source address of the module.

AT Command: ATMY

Binary Command: 0x2A (42 decimal)

Parameter Range: 0 – 0xFFFF

Default Parameter Value: 0xFFFF (Disabled – DT (Destination Address) parameter serves as both source and destination address.)

Number of bytes returned: 2

Related Commands: DT (Destination Address), HP (Hopping Channel), ID (Modem VID), MK (Address Mask)

NB (Parity) Command

<Serial Interfacing> Select/Read parity settings for UART communications.

AT Command: ATNB

Binary Command: 0x23 (35 decimal)

Parameter Range: 0 – 4

Parameter Value	Configuration
0	8-bit (no parity or 7-bit (any parity))
1	8-bit even
2	8-bit odd
3	8-bit mark
4	8-bit space

Default Parameter Value: 0

Number of bytes returned: 1

PK (Maximum RF Packet Size) Command

<RF Interfacing> Set/Read the maximum size of RF packets transmitted from a module. The maximum packet size can be used along with the RB and RO parameters to implicitly set the channel dwell time.

If PK is set above 256 and BR is subsequently changed to 0, PK will automatically be lowered to 256 and a warning will be raised (see BR (RF Data Rate) and WN (Warning Data) Commands for details).

Changes to the PK parameter may have a secondary effect on the RB (Packetization Threshold) parameter. RB must always be less than or equal to PK. If PK is changed to a value less than the current value of RB, RB is automatically lowered to be equal to PK.

* When BR = 0 (9600 baud), the maximum PK value is 0x100 (256d). When BR = 1 (115,200 baud), the maximum PK value is 0x800 (2048d).

AT Command: ATPK

Binary Command: 0x29 (41 decimal)

Parameter Range: 0 – 0x800 [Bytes]

Default: 0x100 or 0x800* (256 or 2048 decimal)

Number of bytes returned: 2

Related Commands: BR (RF Data Rate) RB (Packetization Threshold), RO (Packetization Timeout), WN (Warning Data)

PL (Power Level) Command

<RF Interfacing> Set/Read the power level at which the module transmits data.

AT Command: ATPL

Binary Command: 0x3A (58 decimal)

Parameter Range: 0 – 4

Parameter Value	Configuration
0	1 mW
1	10 mW
2	100 mW
3	500 mW
4	1000 mW (1 Watt)

Default Parameter Value: 4

Number of bytes returned: 1

PW (Pin Wake-up) Command

<Sleep (Low Power)> Under normal operation, a module in Cyclic Sleep Mode cycles from an active state to a low-power state at regular intervals until data is ready to be received. If the PW Parameter is set to 1, the SLEEP Pin (pin 8) can be used to awaken the module from Cyclic Sleep. If the SLEEP Pin is de-asserted (low), the module will be fully operational and will not go into Cyclic Sleep.

Once SLEEP is asserted, the module will remain active for the period of time specified by ST (Time before Sleep) Command, and will return to Cyclic Sleep Mode (if no data is ready to be transmitted). PW Command is only valid if Cyclic Sleep has been enabled.

AT Command: ATPW

Binary Command: 0x1D (29 decimal)

Parameter Range: 0 – 1

Parameter Value	Configuration
0	Disabled
1	Enabled

Default Parameter Value: 0

Number of bytes returned: 1

Related Commands: SM (Sleep Mode), ST (Time before Sleep)

RB (Packetization Threshold) Command

<Serial Interfacing> RB Command is used to set/read the character threshold value.

RF transmission begins when data is received in the DI Buffer and either of the following criteria is met:

- RB characters have been received by the UART
- RO character times of silence are detected on the UART receive lines (After receiving at least 1 byte)

If PK (Maximum RF Packet Size) is lowered below the value of RB, RB is automatically lowered to match the PK parameter value. If RO=0, then RB bytes must be received before beginning transmission.

Note: RB and RO criteria only apply to the first packet of a multi-packet transmission. If data remains in the DI Buffer after the first packet, transmissions will continue in a streaming manner until there is no data left in the DI Buffer (UART receive buffer).

AT Command: ATRB

Binary Command: 0x20 (32 decimal)

Parameter Range: 0 – PK Parameter Value (up to 0x800 Bytes)

Default Parameter Value: 0x800 bytes

Number of bytes returned: 2

Related Commands: BR (RF Data Rate), PK (RF Packet Size), RO (Packetization Timeout)

RC (Ambient Power – Single Channel) Command

<Diagnostics> RC Command is used to examine and report the power level on a given channel.

Sample output: -78 dBm [when CF = 0]
4e [when CF = 1]
-78 [when CF = 2]

AT Command: ATRC

Parameter Range (read-only): 0 – 0x31 [dBm]

Number of bytes returned: 1

Related Commands: RM (Ambient Power – All channels)

RE (Restore Defaults) Command

<Diagnostics> RE Command is used to restore all configurable parameters to factory default settings. However, RE Command will not write the default values to non-volatile (persistent) memory. Unless the WR (Write) Command is issued after the RE command, the restored default settings will not be saved in the event of module reset or power-down.

AT Command: ATRE

Binary Command: 0x0E (14 decimal)

RM (Ambient Power – All Channels) Command

<Diagnostics> RM Command is used to examine and report the power levels on all channels. If no parameter is given, then the channels will be scanned once. If a parameter is given, the channels will be repeatedly scanned for that number of seconds (up to 2000d), and the maximum power level seen for each channel is reported (i.e. peak hold).

AT Command: ATRM

Parameter Range: no parameter – 0x7D0 (2000d)

Number of bytes returned: 2

Related Commands: RC (Ambient Power – Single channel)

A graphical spectrum analyzer application can be implemented by repeatedly calling ATRM with no arguments and reading the resultant 50 power levels (easiest to do when CF = 1 or 2).

Sample output [when CF = 0]:

```
Ch 0: -100 dBm
Ch 1: -103 dBm
...
Ch 49: -99 dBm
```

Sample output [when CF = 1]:

```
64
67
...
63
```

Sample output [when CF = 2]:

```
-100
-103
...
-99
```

RN (Delay Slots) Command

<Networking & Security> RN Command is used to set/read the time delay that the transmitting module inserts before attempting to resend a packet. If the transmitting module fails to receive an acknowledgement after sending a packet, it inserts a random number of delay slots (ranging from 0 to (RN minus 1)) before attempting to resend the packet. Each delay slot lasts for a period of 38 ms.

AT Command: ATRN

Binary Command: 0x19 (25 decimal)

Parameter Range: 0 – 0xFF [38 ms slots]

Default Parameter Value: 0 (no delay slots inserted)

Number of bytes returned: 1

Related Commands: RR (Retries), TT (Streaming Limit)

If two modules attempt to transmit at the same time, the random time delay after packet failure allows only one module to transmit the packet successfully; while the other module waits until the channel available for RF transmission.

RN Command is only applicable if retries have been enabled [RR (Retries) Command] or if forced delays will be inserted into a transmission [TT (Streaming Limit) Command].

RO (Packetization Timeout) Command

<Serial Interfacing> RO Command is used to set/read the Packetization Timeout setting. RF transmission commences when data is in the DI buffer and either of the following criteria are met:

- RO character times of silence on the UART receive lines (after receiving at least 1 byte)
- RB characters have been received by the UART

AT Command: ATRO

Binary Command: 0x21 (33 decimal)

Parameter Range: 0 – 0xFFFF
[x UART character times]

Default Parameter Value: 0x03 (3 decimal)

Number of bytes returned: 2

Related Commands: RB (Packetization Threshold)

RB and RO criteria only apply to the first packet of a multi-packet transmission. If data remains in the DI Buffer (UART receive) after the first packet, transmissions will continue in a streaming manner until there is no data left in the DI Buffer (UART receive).

RO Command (continued)

When RO is the transmission-beginning criteria: The actual time between the reception of the last character from the UART and the beginning of RF transmission will be at least 800 µsec longer than the actual RO time to allow for transmission setup. Additionally, it is subject to 100-200 µsec of additional uncertainty, which could be significant for small values of RO at high UART bit rates.

The RO timer calculates the correct UART character time (10, 11, or 12 bits) based on the following criteria:

- 1 start bit
- 8 data bits
- 0 or 1 parity bit [as determined by the NB (Parity) Command]
- 1 or 2 stop bits [as determined by SB (Stop Bits) Command]

RP (RSSI PWM Timer) Command

RP Command is used to enable a PWM (“Pulse Width Modulation”) output on Pin 11 (Config/RSSI). The pin is calibrated to show the difference between received signal strength and the sensitivity level of the module. PWM pulses vary from zero to 95 percent. Zero percent means the received RF signal is at or below the published sensitivity level of the module. The following table shows dB levels above sensitivity and PWM values:

AT Command: ATRP
Binary Command: 0x22 (34 decimal)
Parameter Range: 0 – 0xFF [x 100 milliseconds]
Default Parameter Value: 0x20 (32 decimal)
Number of bytes returned: 1

The total time period of the PWM output is 8.32 ms. PWM output consists of 40 steps and therefore the minimum step size is 0.208 ms.

dBm above Sensitivity	PWM percentage (high period / total period)
10	20%
20	35%
30	50%

A non-zero value defines the time that PWM output is active with the RSSI value of the last received RF packet. After the set time when no RF packets are received, PWM output is set low (0 percent PWM) until another RF packet is received. PWM output is also set low at power-up. A parameter value of 0xFF permanently enables PWM output and always reflects the value of the last received RF packet.

Pin 11 is shared between PWM output and Config input. When the module is powered, the Config pin is an input. During the power-up sequence, if RP parameter is a non-zero value, the Config pin is configured as an output and set low until the first RF packet is received. With a non-zero RP parameter, the Config pin is an input for RP ms after power up.

RR (Retries) Command

<Networking & Security> RR Command is used to set/read the number of retries that can be sent for a given RF packet. When RR Command is enabled (non-zero value) and when MT Command equals zero, RF packet acknowledgements and retries are enabled.

AT Command: ATRR
Binary Command: 0x18 (24 decimal)
Parameter Range: 0 – 0xFF
Default Parameter Value: 0x0A (10 decimal)
Number of bytes returned: 1

After transmitting a packet, the transmitting module waits to receive an acknowledgement from a receiving module. If the acknowledgement is not received in the period of time specified by RN (Delay Slots) Command, the original packet is transmitted again. The RF packet is transmitted repeatedly until an acknowledgement is received or until the packet is sent RR times.

RT (GPI 1 Configuration) Command

RT Command is used to set/read the behavior of the GPI1 pin (pin 10). The pin can be configured to enable binary programming or $\overline{\text{RTS}}$ flow control.

AT Command: ATRT
 Binary Command: 0x16 (22 decimal)
 Parameter Range: 0 – 2

Parameter Value	Configuration
0	disabled
1	Enable Binary Programming
2	Enable $\overline{\text{RTS}}$ Flow Control

Default Parameter Value: 0
 Number of bytes returned: 1

SB (Stop Bits) Command

<Serial Interfacing> SB Command is used to set/read the number of stop bits in the data packets.

AT Command: ATSB
 Binary Command: 0x37 (55 decimal)
 Parameter Range: 0 – 1

Parameter Value	Configuration
0	1 stop bit
1	2 stop bits

Default Parameter Value: 0
 Number of bytes returned: 1

SH (Serial Number High) Command

<Diagnostics> SH Command is used to set/read the serial number high word of the module.

AT Command: ATSH
 Binary Command: 0x25 (37 decimal)
 Parameter Range (read-only): 0 – 0xFFFF
 Number of bytes returned: 2
 Related Commands: SL (Serial Number Low)

SL (Serial Number Low) Command

<Diagnostics> SL Command is used to set/read the serial number low word of the module.

AT Command: ATSL
 Binary Command: 0x26 (38 decimal)
 Parameter Range (read-only): 0 – 0xFFFF
 Number of bytes returned: 2
 Related Commands: SH (Serial Number High)

SM (Sleep Mode) Command

<Sleep Mode (Low Power)> SM Command is used to set/read the module's Sleep Mode settings that configure the module to run in states that require minimal power consumption.

Pin Sleep (SM = 1)

Next to Shutdown Mode, Pin Sleep requires the least amount of power. In order to achieve this state, SLEEP (pin 8) must be asserted (high). The module remains in Pin Sleep until the SLEEP pin is de-asserted.

After enabling Pin Sleep (SM=1), GPI2 controls whether the XTend Module is active or in Sleep Mode. When GPI2 is de-asserted (low), the module is fully operational. When GPI2 is asserted (high), the module transitions to Sleep Mode and remains in its lowest power-consuming state until the Sleep pin is de-asserted. GPI2 is only active if the module is setup to operate in this mode; otherwise the pin is ignored.

Once in Pin Sleep Mode, GP01 (pin 9, $\overline{\text{CTS}}$) is de-asserted (high), indicating that data should not be sent to the module. PWR (pin 4) is also de-asserted (low) when the module is in Pin Sleep Mode.

Note: The module will complete a transmission or reception before activating Pin Sleep.

Serial Port Sleep (SM = 2)

Serial Port Sleep is a Sleep Mode in which the XTend Module runs in a low power state until serial data is detected on the DI pin.

When Serial Port Sleep is enabled, the module goes into Sleep Mode after a user-defined period of inactivity (no transmitting or receiving of data). This period of time is determined by ST (Time before Sleep) Command. Once a character is received through the DI pin, the module returns to Idle Mode and is fully operational.

Cyclic Sleep (SM = 4-8)

Cyclic Sleep is the Sleep Mode in which the XTend Module enters into a low-power state and awakens periodically to determine if any transmissions are being sent. Cyclic sleep settings wake the module after the amount of time designated by the associated SM parameter values. If the module detects a wake-up initializer during the time it is awake, the module synchronizes with the transmitting module and starts receiving data after the wake-up initializer runs its duration. Otherwise, the module returns to Sleep Mode and continues to cycle in and out of activity until a wake-up initializer is detected. If a Cyclic Sleep setting is chosen, the ST, LH and HT parameters must also be set as described in the "Sleep Mode" section of this manual.

When Cyclic Sleep settings are enabled, the XTend Module goes into Sleep Mode after a user-defined period of inactivity (no transmission or reception on the RF channel). The user-defined period is determined by ST (Time before Sleep) Command.

While the module is in Cyclic Sleep Mode, GP01 (pin 9, $\overline{\text{CTS}}$) is de-asserted (high) to indicate that data should not be sent to the module during this time. When the module awakens to listen for data, GP01 is asserted and any data received on the DI Pin is transmitted. PWR (pin 4) is also de-asserted (low) when the module is in Cyclic Sleep Mode.

AT Command: ATSM

Binary Command: 0x01

Parameter Range: 0 – 8

Parameter Value	Configuration
0	Disabled
1	Pin Sleep
2	Serial Port Sleep
3	reserved
4	Cyclic 1.0 second sleep (Module wakes every 1.0 second)
5	Cyclic 2.0 second sleep
6	Cyclic 4.0 second sleep
7	Cyclic 8.0 second sleep
8	Cyclic 16.0 second sleep

Default Parameter Value: 0

Number of bytes returned: 1

Related Commands:

Pin Sleep – PC (Power-up Mode), PW (Pin Wake-up)

Serial Port Sleep – ST (Time before Sleep)

Cyclic Sleep – ST (Time before Sleep), LH (Wake-up Initializer Timer), HT (Time Before Wake-up Initializer), PW (Pin Wake-up)

SM Command (continued)

The module remains in Sleep Mode for a user-defined period of time ranging from 0.5 seconds to 16 seconds (SM Parameters 3 through 8). After this interval of time, the module returns to Idle Mode and listens for a valid data packet for 100 ms. If the module does not detect valid data (on any frequency), the module returns to Sleep Mode. If valid data is detected, the module transitions into Receive Mode and receives incoming RF packets. The module then returns to Sleep Mode after a Period of inactivity that is determined by ST “Time before Sleep” Command.

The module can also be configured to wake from cyclic sleep when GPI2 (pin 8, SLEEP) is de-asserted (low). To configure a module to operate in this manner, PW (Pin Wake-up) Command must be issued. Once GPI2 is de-asserted, the module is forced into Idle Mode and can begin transmitting or receiving data. It remains active until no data is detected for the period of time specified by the ST Command, at which point it resumes its low-power cyclic state.

Note: The cyclic interval time defined by SM (Sleep Mode) Command must be shorter than the interval time defined by LH (Wake-up Initializer Timer).

For example: If SM=4 (Cyclic 1.0 second sleep), the LH Parameter should equal 0xB (“1.1” seconds). With these parameters set, there is no risk of the receiving module being asleep for the duration of wake-up initializer transmission. “Cyclic Scanning” explains in further detail the relationship between “Cyclic Sleep” and “Wake-up Initializer Timer”

Cyclic Scanning. Each RF transmission consists of an RF Initializer and payload. The wake-up initializer contains initialization information and all receiving modules must wake during the wake-up initializer portion of data transmission in order to be synchronized with the transmitting module and receive the data.

Figure 3.1. Correct Configuration (LH > SM):

Length of the wake-up initializer exceeds the time interval of Cyclic Sleep. The receiver is guaranteed to detect the wake-up initializer and receive the accompanying payload data.

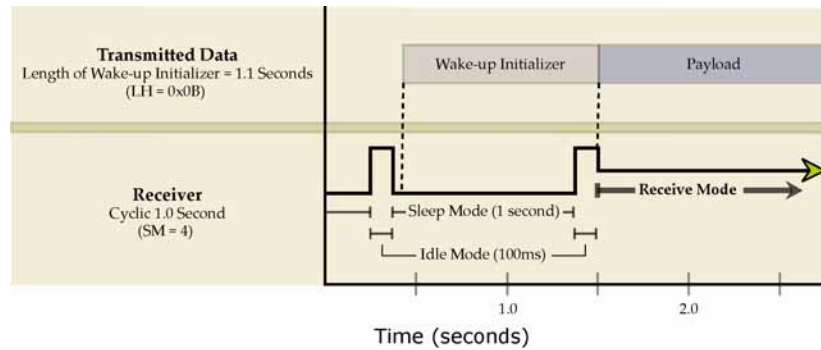
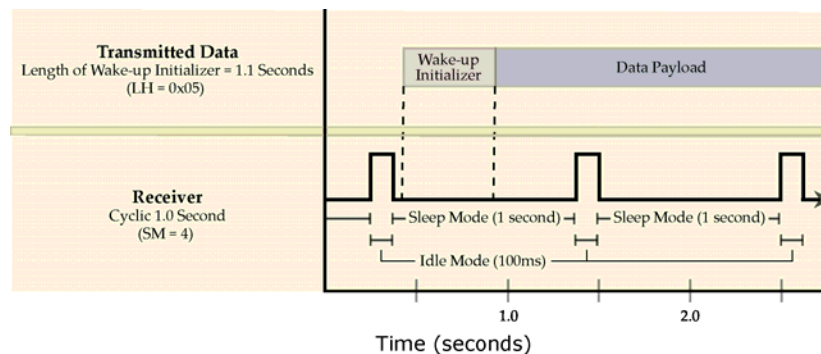

Figure 3.2. Incorrect Configuration (LH < SM):

Length of wake-up initializer is shorter than the time interval of Cyclic Sleep. This configuration is vulnerable to the receiver waking and missing the wake-up initializer (and therefore also the accompanying payload data).



ST (Time before Sleep) Command

<Sleep Mode (Low Power)> ST Command is used to set/read the period of time (milliseconds) in which the module remains inactive before entering Sleep Mode.

For example, if the ST Parameter is set to 0x64 (100 decimal), the module will enter into Sleep mode after 10 seconds of inactivity (no transmitting or receiving).

This command can only be used if Cyclic Sleep or Serial Port Sleep Mode settings have been selected using SM (Sleep Mode) Command.

AT Command: ATST
 Binary Command: 0x02 (2 decimal)
 Parameter Range: (ATAT+3) - 0x7FFF
 [x 100 milliseconds]
 Default Parameter Value: 0x64 (100 decimal)
 Number of bytes returned: 2
 Related Commands: SM (Sleep Mode), LH (Wake-up Initializer Timer), HT (Time before Wake-up Initializer)

TP (Board Temperature) Command

<Diagnostics> TP Command is used to read the current temperature of the board.

Sample Output: 26 C [when ATCF = 0]
 1A [when ATCF = 1]
 26 [when ATCF = 2]

AT Command: ATTP
 Binary Command: 0x38 (56 decimal)
 Parameter Range (read-only): 0- 0x7F
 Number of bytes returned: 1
 Related Commands: WN (Warning Data)

TR (Transmit Error Count) Command

<Diagnostics> TR Command is used to report the number of retransmit failures. This number is incremented each time a packet is not acknowledged within the number of retransmits specified by RR (Retries) Command. It therefore counts the number of packets that were not successfully received and were subsequently dropped.

TR Parameter is not non-volatile and will therefore be reset to zero when the module is reset.

AT Command: ATTR
 Binary Command: 0x1B (27 decimal)
 Parameter Range: 0 - 0xFFFF
 Default Parameter Value: 0
 Number of bytes returned: 2
 Related Commands: RR (Retries)

TT (Streaming Limit) Command

<Networking & Security> TT Command is used to set/read the limit on the number of bytes that can be sent out before a random delay is issued.

If a module is sending a continuous stream of RF data, a delay is inserted which stops its transmission and allows other modules time to transmit (once it sends TT bytes of data).

Inserted random delay lasts between 1 & 'RN + 1' delay slots, where each delay slot lasts 38 ms.

TT command can be used to simulate full-duplex behavior.

AT Command: ATTT
 Binary Command: 0x1A (26 decimal)
 Parameter Range: 0 - 0xFFFF
 Default Parameter Value: 0 (disabled)
 Number of bytes returned: 2
 Related Commands: RN (Delay Slots)

TX (Transmit Only) Command

<RF Interfacing> TX Command is used to set/read the transmit/receive behaviors of the module. Setting a module to TX-only may reduce latency because the transmitting module will never be "stuck" receiving data from other modules.

AT Command: ATTX
 Binary Command: 0x3F (63 decimal)
 Parameter Range: 0 - 1

Parameter Value	Configuration
0	TX and RX
1	TX only

Default Parameter Value: 0
 Number of bytes returned: 1

VL (Firmware Version - verbose) Command

<Diagnostics> VL Command is used to read the verbose firmware version of the XTend Module.
 Sample output: Firmware version 1.0, Jan 16 2005 10:46:57

AT Command: ATVL
 Parameter Range: Returns string
 Number of bytes returned: 2

VR (Firmware Version) Command

<Diagnostics> VR Command is used to read the firmware version of the XTend Module.

AT Command: ATVR
 Binary Command: 0x14 (20 decimal)
 Parameter Range (read-only): 0 - 0xFFFF
 Number of bytes returned: 2

WA (Active Warning Numbers) Command

<Diagnostics> WA Command reports the warning numbers of all active warnings - one warning number per line. No further information is shown and warning counts are not reset.

AT Command: ATWA
 Parameter Range: Returns string - one warning number per line.

Sample Output (indicates warnings 1 and 3 are currently active):
 1
 3
 OK

WN (Active Warning Numbers) Command

<Diagnostics> WN Command is used to report detailed data for all active and sticky warnings.

AT Command: ATWN
 Parameter Range: Returns string

- Warning number & description
- Number of occurrences since the last WN or WS command
- Whether the warning is currently active

Warnings which are not currently active, and have not been active since the last WN or WS command, are not displayed. WN Command also resets all non-zero warning counts, except for warnings that are presently active, which are set to 1.

Sample output: Warning 1: Under-voltage
 3 occurrences; presently active
 Warning 4: Over-temperature
 5 occurrences; presently inactive.

Warning Number	Description
1	Under-voltage. This is caused if the supply voltage falls below the minimum threshold for the lowest power level (2.8 V). If/when the voltage rises above the threshold, the warning is deactivated. The module will not transmit below this voltage threshold.
2	Over-voltage. This is caused if the supply voltage exceeds 5.75 V. Transmission is not allowed while this warning is active.
3	Under-temperature. This is caused if the temperature sensed by the module is less than -40 C. The module does not artificially limit operation while this warning is active, but module functionality is not guaranteed.
4	Over-temperature. This is caused if the temperature sensed by the module is greater than 105 C. The module does not allow transmission nor reception while this warning is active. The warning is deactivated when the temperature falls to 100 C.
5	Power reduced. This is caused if the transmit power has to be reduced from the level programmed by PL Command due to insufficient supply voltage. The 1 W power level requires 4.75 V or higher; 500 mW requires 3.0 V or higher; 100 mW, 10 mW and 1 mW require 2.8 V or higher.
6	Default calibration data in flash. This is caused if the module-specific power calibration data is either not present or is invalid, or if none of the parameters have been modified from their default values. Power levels may be incorrect.
7	Default configuration parameters in flash. This is caused if the user-modifiable parameters (i.e. those stored by a 'WR' command) in flash are all the compiled-in default values. This is caused if the user configuration is found to be not present or invalid at power-up and there is no user custom configuration, or if no user-modifiable parameters have been modified from the compiled-in defaults. Note that modification of one or more parameters without the subsequent ATWR to commit the changes to flash will not deactivate this warning, since it reflects the status of the parameters in flash. Note as well that this warning does not reflect usage of the custom configuration defaults, only usage of the compiled-in defaults.
8	Default factory configuration parameters in flash. This is caused if the factory parameters in flash are all the default values. This is caused if the factory configuration is found to be not present or invalid at power-up, or if no factory parameters have been modified.

WR (Write) Command

<(Special)> WR Command writes configurable parameters to the module's non-volatile memory (Parameter values remain in the modem's memory until overwritten by future use of WR Command).

AT Command: ATWR

Binary Command: 0x08

If changes are made without writing them to non-volatile memory, the module reverts back to previously saved parameters the next time the module is powered-on.

WS (Sticky Warning Numbers) Command

<Diagnostics> WS Command reports the warning numbers of all warnings which have been active since the last use of WS or WN command, including any warnings which are currently active. No further information is shown.

AT Command: ATWS

Parameter Range (read-only): 1 - 8

Number of bytes returned: 1

This command also resets all non-zero warning counts, except for warnings that are presently active, which are set to 1.

4. RF Communication Modes

The XTend OEM RF Module can be configured to operate in any of three RF communication modes: Streaming, Acknowledged and Multi-Transmit. The mode is defined by parameters stored in the transmitting module [see table below]. Receiving modules automatically adapt to the correct mode on a per-packet basis, based on the contents of each received packet.

Table 4.1. Mode in Relation to Transmitting Module Parameter Values

RF Communication Mode	RR Parameter Value	MT Parameter Value
Streaming	0	0
Acknowledged	>= 1	0
Multi-transmit	Ignored	>= 1

4.1. Addressing Options

Transmissions can be addressed to a specific module or group of modules using the DT (Destination Address) and MK (Address Mask) commands. A receiving module will only accept a packet if it determines the packet is addressed to it, either as a global or local packet. The receiving module makes this determination by inspecting the destination address of the packet and comparing it to its own address and address mask [Figure 4.1]

Figure 4.1. Address Recognition (@ the Receiving Module)

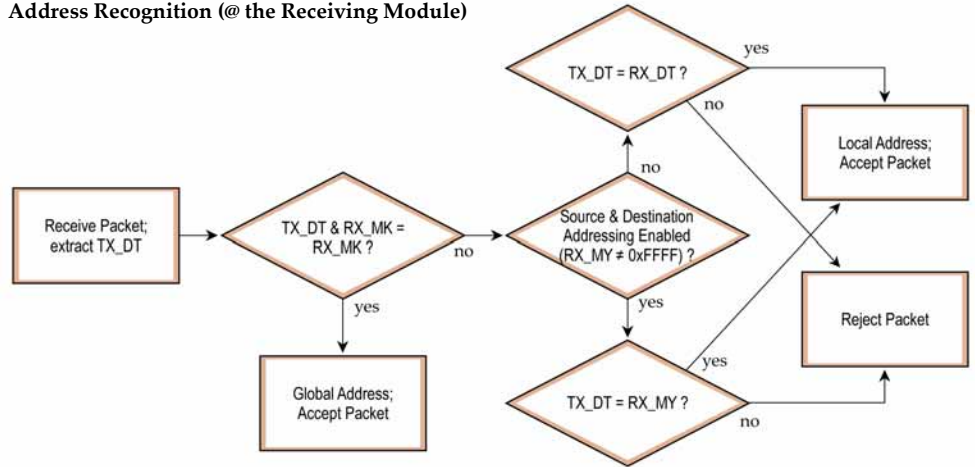

The transmitting module determines whether the packet is intended for a specific node (local address) or multiple nodes (global address) by comparing the packet’s destination address (DT) and its own address mask (MK) [Figure 4.2]. It is assumed that the address masks on the transmitting module and receiving module have been programmed to the same value for proper operation in each RF Communication Mode.

Figure 4.2. Address Recognition (@ the Transmitting Module)

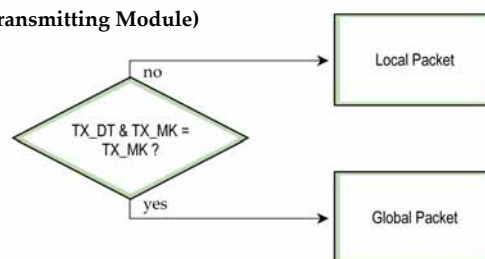

4.2. Streaming Mode

- Attributes:**
- Highest data throughput
 - Lowest latency and jitter
 - Reduced immunity to interference
 - Streaming mode transmissions never acknowledged by receiving module(s)

Required Parameter Values (TX Module): RR (Retries) = 0

Related Commands: Networking (DT, MK, MY), Serial Interfacing (PK, RB, RO, TT)

Recommended Use: Mode is most appropriate for data that is more sensitive to latency and/or jitter than it is to occasional packet loss. For example: streaming audio or video.

4.2.1. Streaming Mode Connection Sequence

Events through the “Transmit Packet” process are common to all RF communication options. Refer to the Transmit Mode section [p11] for more information.

When streaming data, RB and RO parameters are used only on the first packet. After transmission begins, the TX event will continue uninterrupted until the DI buffer is empty or the streaming limit (TT Command) is reached. As with the first packet, the payload of each subsequent packet includes up to the maximum packet size (PK Command).

The streaming limit is specified by the

transmitting module as the maximum number of bytes the transmitting module can send in one transmission event. If the TT parameter is reached, the transmitting module will force a random delay of 1 to RN delay slots (exactly 1 delay slot if RN=0).

Subsequent packets are sent without an RF initializer since receiving modules stay synchronized with the transmitting module for the duration of the transmission event (from preceding packet information). However, due to interference, some receiving modules may lose data (and synchronization to the transmitting module), particularly during long transmission events.

Once the transmitting module has sent all pending data or has reached the TT limit, the transmission event ends. The transmitting module will not transmit again for exactly RN delay slots if the local (i.e. transmitting module’s) RN parameter is set to a non-zero value. The receiving module(s) will not transmit for a random number of delay slots between 0 and (RN-1) if the local (i.e. receiving module’s) RN parameter is set to a non-zero value. These delays are intended to lessen congestion following long bursts of packets from a single transmitting module, during which several receiving modules may have become ready to transmit.

Figure 4.3. Streaming Mode State Diagram

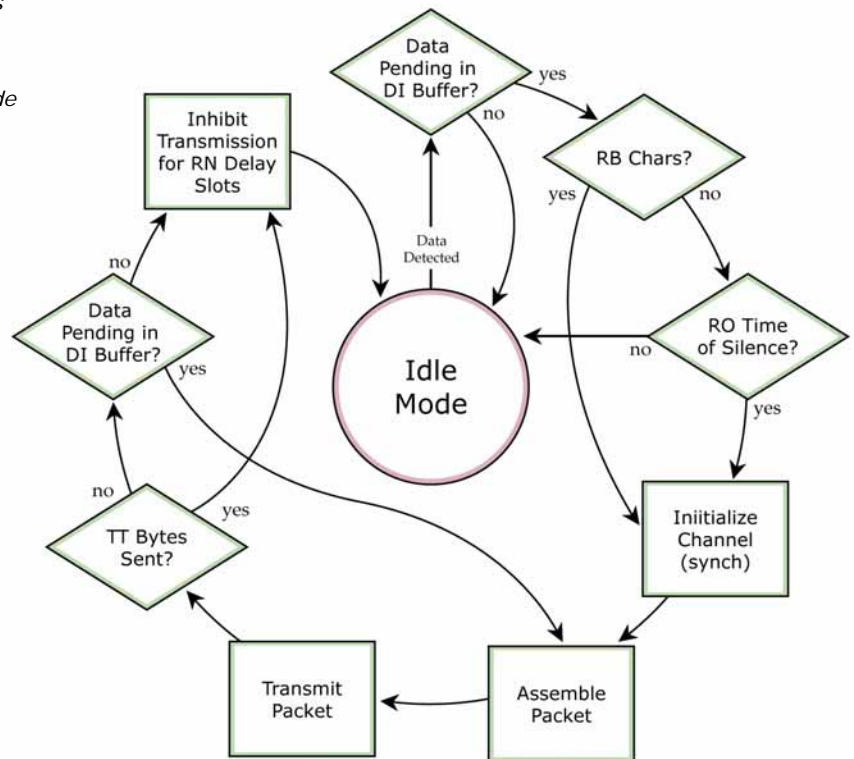

4.3. Acknowledged Mode

Attributes: Reliable delivery through positive acknowledgements for each packet
Throughput, latency and jitter vary depending on the quality of the channel and the strength of the signal.

Required Parameter Values (TX Module): RR (Retries) >= 1

Related Commands: Networking (DT, MK, RR), Serial Interfacing (PK, RN, RO, RB, TT)

Recommended Use: Use for applications that require Reliable Delivery. If messages are smaller than 256 bytes, use RB and RO commands to align RF packets to application packets.

4.3.1. Acknowledged Mode Connection Sequence

Events through the “Transmit Packet” process are common to all RF communication options. Refer to the Transmit Mode section [p11] for more information.

After sending a packet while in acknowledged mode, the transmitting module listens for an acknowledgement. If it receives the ACK, it will either move on to sending a subsequent packet (if more transmit data is pending), or will wait for exactly RN random delay slots before allowing another transmission (if no more data is pending to be transmitted).

If the transmitting module does not receive the ACK within the allotted time, it will retransmit the packet with a new RF initializer following the ACK slot. There is no delay between the first ACK slot and the first retransmission. Subsequent retransmissions incur a delay of a random number of delay slots, between 0 and RN. If RN is set to 0 on the transmitting module, there are never any back-off delays between retransmissions. Note that during back-off delays, the transmitting module will go into Idle Mode and may receive RF data. This can have the effect of increasing the back-off delay, as the radio cannot return to RF transmit (or retransmit) mode as long as it is receiving RF data.

After receiving and acknowledging a packet, the receiving module will move to the next frequency and listen for either a retransmission or new data, for a specific period of time. Even if the transmitting module has indicated that it has no more pending transmit data, it may have not received the previous ACK, and so may retransmit the packet, possibly with no delay after the ACK slot. In this case, the receiving module will always detect the immediate retransmission, which will hold off the communications channel and thereby reduce collisions. Receiving modules acknowledge each retransmission they receive, but they only pass the first copy of a packet they receive out the UART.

Figure 4.4. Acknowledged Mode State Diagram

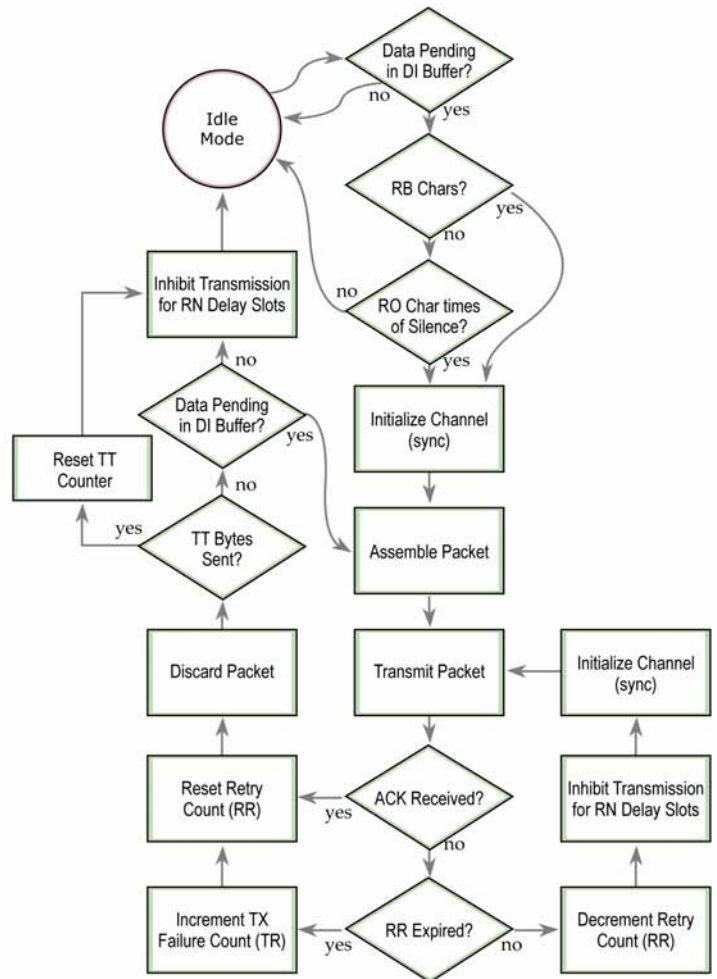

RB and RO parameters are not applied to subsequent packets, meaning that once transmission has begun, it will continue uninterrupted until the DI buffer is empty or the streaming limit (TT) has been reached. As with the first packet, the payload of each subsequent packet includes up to the maximum packet size (PK), and the transmitting module checks for more pending data near the end of each packet.

The streaming limit (TT) specifies the maximum number of bytes that the transmitting module will send in one transmission event, which may consist of many packets and retries. If the TT parameter is reached, the transmitting module will force a random delay of 1 to RN delay slots (exactly 1 delay slot if RN is zero). Each packet is counted only once toward TT, no matter how many times the packet is retransmitted.

Subsequent packets in acknowledged mode are similar to those in streaming mode, with the addition of an acknowledgement between each packet, and the possibility of retransmissions. Subsequent packets are sent without an RF initializer, as the receiving modules are already synchronized to the transmitting module from the preceding packet(s) and they remain synchronized for the duration of the transmission event. Each retransmission of a packet includes an RF initializer.

Once the transmitting module has sent all pending data or has reached the TT limit, the acknowledged transmission event is completed. The transmitting module will not transmit again for exactly RN delay slots, if the local RN parameter is set to a nonzero value. The receiving module will not transmit for a random number of delay slots between 0 and (RN-1), if the local RN parameter is set to a nonzero value. These delays are intended to lessen congestion following long bursts of packets from a single transmitting module, during which several receiving modules may have themselves become ready to transmit.

4.4. Multi-Transmit Mode

Attributes: Reliable Delivery through forced transmission of every RF packet
 Every RF packet is sent exactly (MT + 1) times with no delays between packets
 Diminished throughput and increased latency

Required Parameter Values (TX Module): MT (Multi-Transmit) >= 1

Other Related Commands: Networking (DT, MK, MY, RN, TT), Serial Interfacing (BR, PK, RB, RO), RF Interfacing (FS)

Recommended Use: Use for applications that require Reliable Delivery without using retries and acknowledgements.

4.4.1. Multi-Transmit Mode Connection Sequence

Events through the “Transmit Packet” process are common to all RF communication options. Refer to the Transmit Mode section [p11] for more information.

In Multi-Transmit mode, each packet is retransmitted MT times, for a total of (MT+1) transmissions. There is no delay between retransmissions, and the transmitting module will never receive RF data between retransmissions. Each retransmission includes an RF initializer. A transmission event may include follow-on packets, each of which will be retransmitted MT times. The Forced Sync (FS) parameter is ignored in multiple-transmission mode.

The RB and RO parameters are not applied to follow-on packets, meaning that once transmission has begun, it will continue uninterrupted until the DI buffer is empty or the streaming limit (TT) has been reached. As with the first packet, the payload of each follow-on packet includes up to the maximum packet size (PK) bytes, and the transmitting module checks for more pending data near the end of each packet. Follow-on packets are not sent until all retransmissions of the previous packet are finished.

The streaming limit (TT) is specified at the transmitting module as the maximum number of bytes that the transmitting module can send in one transmission event, which may consist of many packets. If the TT parameter is reached, the transmitting module will force a random delay of 1 to RN delay slots (exactly 1 delay slot if RN is zero). In Multi-Transmit mode, each packet is counted only once when tracking the streaming limit (TT), no matter how many times it is retransmitted.

When a receiving module receives a Multi-Transmit packet, it calculates the amount of time remaining in the Multi-Transmit event, and inhibits its own transmissions for the duration of the Multi-Transmit event, plus a random number of delay slots between 0 and (RN-1). If the local RN parameter is zero, the delay is only for the calculated duration of the Multi-Transmit event. Thus, a receiving module need only receive one of the transmissions, and it will keep off the channel until the transmitting module is done. If follow-on packets are coming, the receiving modules will move to the new frequency and listen for the follow-on packet for a specific period of time.

Figure 4.5. Multi-Transmit Mode State Diagram

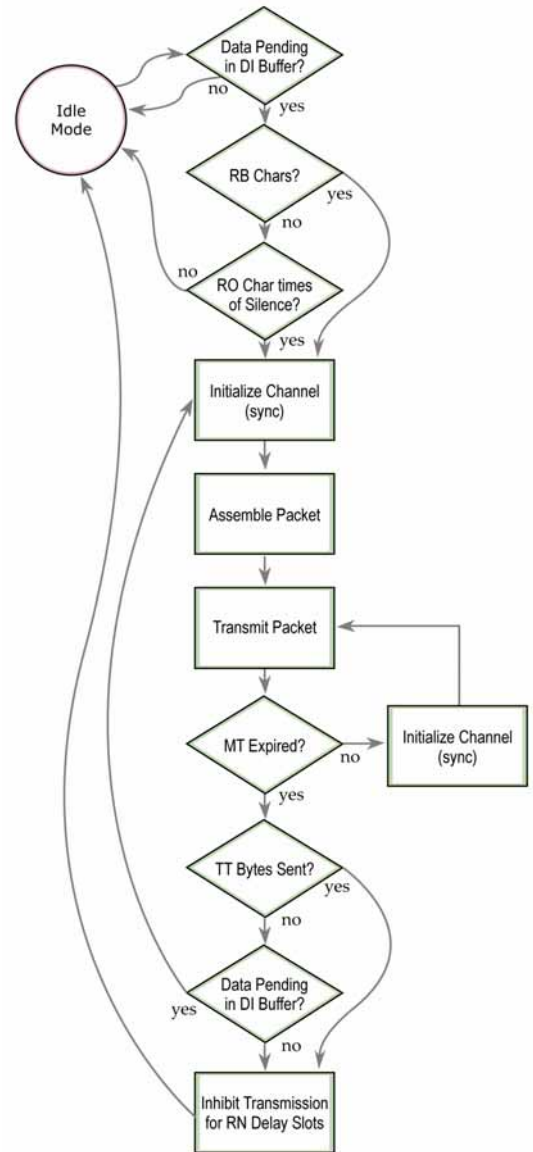

Appendix A: Agency Certifications

FCC Certification

The XTend OEM RF Module complies with Part 15 of the FCC rules and regulations. Compliance with labeling requirements, FCC notices and antenna regulations is required.

Labeling Requirements

In order to inherit MaxStream’s FCC Certification, OEMs and integrators are required to publish the text shown in Figure A-01 on the final product and within the final product operation manual.

Label Warning

 WARNING The Original Equipment Manufacturer (OEM) must ensure that FCC labeling requirements are met. This includes a clearly visible label on the outside of the final product enclosure that displays the contents shown in the figure below.
--

Figure A.1. Required FCC Label for OEM products containing the 9XTend (900 MHz) OEM RF Module

Contains FCC ID: OUR-9XTEND The enclosed device complies with Part 15 of the FCC Rules. Operation is subject to the following two conditions: (1) this device may not cause harmful interference and (2) this device must accept any interference received, including interference that may cause undesired operation.

FCC Notices

Adherence to the following is required:

IMPORTANT: The XTend OEM RF Modules have been certified by the FCC for use with other products without any further certification (as per FCC section 2.1091). Changes or modifications not expressly approved by MaxStream could void the user’s authority to operate the equipment.

IMPORTANT: OEMs must test their final product to comply with unintentional radiators (FCC section 15.107 and 15.109) before declaring compliance of their final product to Part 15 of the FCC Rules.

IMPORTANT: The XTend OEM RF Modules have been certified for fixed base station and mobile applications. If modules will be used for portable applications, the device must undergo SAR testing.

NOTE:

This equipment has been tested and found to comply with the limits for a Class B digital device, pursuant to Part 15 of the FCC Rules. These limits are designed to provide reasonable protection against harmful interference in a residential installation. This equipment generates, uses and can radiate radio frequency energy and, if not installed and used in accordance with the instructions, may cause harmful interference to radio communications. However, there is no guarantee that interference will not occur in a particular installation. If this equipment does cause harmful interference to radio or television reception, which can be determined by turning the equipment off and on, the user is encouraged to try to correct the interference by one or more of the following measures:

- Reorient or relocate the receiving antenna.
- Increase the separation between the equipment and receiving module.
- Connect the equipment into an outlet on a circuit different from that to which the receiving module is connected.
- Consult the dealer or an experienced radio/TV technician for help.

Antenna Warning

 WARNING: This device has been tested with Reverse Polarity SMA connectors with the antennas listed in Tables A.1 – A.7 of Appendix A. When integrated into OEM products, fixed antennas require installation preventing end-users from replacing them with non-approved antennas. Antennas not listed in the tables must be tested to comply with FCC Section 15.203 (unique antenna connectors) and Section 15.247 (emissions).

Limited Modular Approval

Power output is conducted at the antenna terminal and can be adjusted from 1 mill-watt to 1 Watt at the OEM level. This is an OEM RF Module approved for Limited Modular use operating as a mobile transmitting device with respect to section 2.1091 and is limited to OEM installation for Mobile and Fixed applications only. During final installation, end-users are prohibited from access to any programming parameters. Professional installation adjustment is required for setting module power and antenna gain to meet EIRP compliance for high gain antenna(s).

Final antenna installation and operating configurations of this transmitter including antenna gain and cable loss must not exceed the EIRP of the configuration used for calculating MPE. Grantee (MaxStream) must coordinate with OEM integrators to ensure the end-users and installers of products operating with the module are provided with operating instructions to satisfy RF exposure requirements.

The FCC grant is valid only when the device is sold to OEM integrators. The OEM integrators are instructed to ensure the end-user has no manual instructions to remove, adjust or install the device.

FCC-Approved Antennas (900 MHz)

Fixed Base Station and Mobile Applications

MaxStream Modules are pre-FCC approved for use in fixed base station and mobile applications. When the antenna is mounted at least 20 cm (8”) from nearby persons, the application is considered a mobile application.

Portable Applications and SAR Testing

When the antenna is mounted closer than 20 cm to nearby persons, then the application is considered “portable” and requires an additional test be performed on the final product. This test is called the Specific Absorption Rate (SAR) testing and measures the emissions from the module and how they affect the person.

RF Exposure

(This statement must be included as a CAUTION statement in OEM product manuals.)

 **WARNING:** This equipment is approved only for mobile and base station transmitting devices. Antenna(s) used for this transmitter must be installed to provide a separation distance of at least 30 cm from all persons and must not be co-located or operating in conjunction with any other antenna or transmitter.

NOTE: The separation distance indicated in the above is 30 cm, but any distance greater than or equal to 23 cm can be used (per MPE evaluation).

To fulfill FCC Certification requirements:

1. Integrator must ensure required text [Figure A.1] is clearly placed on the outside of the final product.
2. XTend Module may be used only with Approved Antennas that have been tested with this module. [Refer to Tables A.1 – A.7]

1 Watt Transmit Power Output or Lower

Table A.1. Half-wave antennas (approved when operating at 1 Watt power output or lower.)

Part Number	Type	Connector	Gain	Application
A09-HSM-7	Straight half-wave	RPSMA	3.0 dBi	Fixed / Mobile
A09-HASM-675	Articulated half-wave	RPSMA	2.1 dBi	Fixed / Mobile
A09-HABMM-P6I	Articulated half-wave w/ 6" pigtail	MMCX	2.1 dBi	Fixed / Mobile
A09-HABMM-6-P6I	Articulated half-wave w/ 6" pigtail	MMCX	2.1 dBi	Fixed / Mobile
A09-HBMM-P6I	Straight half-wave w/ 6" pigtail	MMCX	2.1 dBi	Fixed / Mobile
A09-HRSM	Right angle half-wave	RPSMA	2.1 dBi	Fixed
A09-HASM-7	Articulated half-wave	RPSMA	2.1 dBi	Fixed
A09-HG	Glass mounted half-wave	RPSMA	2.1 dBi	Fixed
A09-HATM	Articulated half-wave	RPTNC	2.1 dBi	Fixed
A09-H	Half-wave dipole	RPSMA	2.1 dBi	Fixed

Table A.2. Yagi antennas (approved when operating at 1 Watt power output or lower.)

Part Number	Type	Connector	Gain	Required Antenna Cable Loss	Application
A09-Y6	2 Element Yagi	RPN	6.1 dBi	- 0.1 dB*	Fixed / Mobile
A09-Y7	3 Element Yagi	RPN	7.1 dBi	- 1.1 dB*	Fixed / Mobile
A09-Y8	4 Element Yagi	RPN	8.1 dBi	- 2.1 dB*	Fixed / Mobile
A09-Y6TM	2 Element Yagi	RPTNC	6.1 dBi	- 0.1 dB*	Fixed / Mobile
A09-Y7TM	3 Element Yagi	RPTNC	7.1 dBi	- 1.1 dB*	Fixed / Mobile
A09-Y8TM	4 Element Yagi	RPTNC	8.1 dBi	- 2.1 dB*	Fixed / Mobile

* FCC regulations stipulate a 36 dBm EIRP power requirement. Users implementing antenna gain greater than 6.0 dB must compensate for the added gain with cable loss. When operating at 1 W power output, the sum (in dB) of cable loss and antenna gain shall not exceed 6.0 dB.

Table A.3. Omni-directional base station antennas (approved when operating at 1 Watt power output or lower.)

Part Number	Type	Connector	Gain	Required Antenna Cable Loss	Application
A09-F0	Fiberglass Base Station	RPN	0 dBi	-	Fixed
A09-F1	Fiberglass Base Station	RPN	1.0 dBi	-	Fixed
A09-F2	Fiberglass Base Station	RPN	2.1 dBi	-	Fixed
A09-F3	Fiberglass Base Station	RPN	3.1 dBi	-	Fixed
A09-F4	Fiberglass Base Station	RPN	4.1 dBi	-	Fixed
A09-F5	Fiberglass Base Station	RPN	5.1 dBi	-	Fixed
A09-F6	Fiberglass Base Station	RPN	6.1 dBi	- 0.1 dB*	Fixed
A09-F7	Fiberglass Base Station	RPN	7.1 dBi	- 1.1 dB*	Fixed
A09-F8	Fiberglass Base Station	RPN	8.1 dBi	- 2.1 dB*	Fixed
A09-W7	Wire Base Station	RPN	7.1 dBi	- 1.1 dB*	Fixed
A09-F0	Fiberglass Base Station	RPSMA	0 dBi	-	Fixed
A09-F1	Fiberglass Base Station	RPSMA	1.0 dBi	-	Fixed
A09-F2	Fiberglass Base Station	RPSMA	2.1 dBi	-	Fixed
A09-F3	Fiberglass Base Station	RPSMA	3.1 dBi	-	Fixed
A09-F4	Fiberglass Base Station	RPSMA	4.1 dBi	-	Fixed
A09-F5	Fiberglass Base Station	RPSMA	5.1 dBi	-	Fixed
A09-F6	Fiberglass Base Station	RPSMA	6.1 dBi	- 0.1 dB*	Fixed
A09-F7	Fiberglass Base Station	RPSMA	7.1 dBi	- 1.1 dB*	Fixed
A09-F8	Fiberglass Base Station	RPSMA	8.1 dBi	- 2.1 dB*	Fixed
A09-W7SM	Wire Base Station	RPSMA	7.1 dBi	- 1.1 dB*	Fixed
A09-F0TM	Fiberglass Base Station	RPTNC	0 dBi	-	Fixed
A09-F1TM	Fiberglass Base Station	RPTNC	1.0 dBi	-	Fixed
A09-F2TM	Fiberglass Base Station	RPTNC	2.1 dBi	-	Fixed
A09-F3TM	Fiberglass Base Station	RPTNC	3.1 dBi	-	Fixed
A09-F4TM	Fiberglass Base Station	RPTNC	4.1 dBi	-	Fixed
A09-F5TM	Fiberglass Base Station	RPTNC	5.1 dBi	-	Fixed
A09-F6TM	Fiberglass Base Station	RPTNC	6.1 dBi	- 0.1 dB*	Fixed
A09-F7TM	Fiberglass Base Station	RPTNC	7.1 dBi	- 1.1 dB*	Fixed
A09-F8TM	Fiberglass Base Station	RPTNC	8.1 dBi	- 2.1 dB*	Fixed
A09-W7TM	Wire Base Station	RPTNC	7.1 dBi	- 1.1 dB*	Fixed

Table A.4. Mag Mount antennas (approved when operating at 1 Watt power output or lower.)

Part Number	Type	Connector	Gain	Required Antenna Cable Loss	Application
A09-M0SM	Mag Mount	RPSMA	0 dBi	-	Fixed
A09-M2SM	Mag Mount	RPSMA	2.1 dBi	-	Fixed
A09-M3SM	Mag Mount	RPSMA	3.1 dBi	-	Fixed
A09-M5SM	Mag Mount	RPSMA	5.1 dBi	-	Fixed
A09-M7SM	Mag Mount	RPSMA	7.1 dBi	-1.1 dB*	Fixed
A09-M8SM	Mag Mount	RPSMA	8.1 dBi	-2.1 dB*	Fixed
A09-M0TM	Mag Mount	RPTNC	0 dBi	-	Fixed
A09-M2TM	Mag Mount	RPTNC	2.1 dBi	-	Fixed
A09-M3TM	Mag Mount	RPTNC	3.1 dBi	-	Fixed
A09-M5TM	Mag Mount	RPTNC	5.1 dBi	-	Fixed
A09-M7TM	Mag Mount	RPTNC	7.1 dBi	-1.1 dB*	Fixed
A09-M8TM	Mag Mount	RPTNC	8.1 dBi	-2.1 dB*	Fixed

Table A.5. Multi-path antennas (approved when operating at 1 Watt power output or lower.)

Part Number	Type	Connector	Gain	Application
A09-DPSM-P12F	omni directional permanent mount w/ 12ft pigtail	RPSMA	3.0 dBi	Fixed
A09-D3NF-P12F	omni directional magnetic mount w/ 12ft pigtail	RPN	3.0 dBi	Fixed
A09-D3SM-P12F	omni directional w/ 12ft pigtail	RPSMA	3.0 dBi	Fixed
A09-D3PNF	omni directional permanent mount	RPN	3.0 dBi	Fixed
A09-D3TM-P12F	omni directional w/ 12ft pigtail	RPTNC	3.0 dBi	Fixed
A09-D3PTM	omni directional permanent mount	RPTNC	3.0 dBi	Fixed
A92-D4PNF	900 MHz / 2.4GHz permanent mount	RPN	2.1 dBi	Fixed
A92-D4P	900 MHz / 2.4GHz permanent mount	RPSMA	2.1 dBi	Fixed
A92-D4PTM	900 MHz / 2.4GHz permanent mount	RPTNC	2.1 dBi	Fixed

* FCC regulations stipulate a 36 dBm EIRP power requirement. Users implementing antenna gain greater than 6.0 dB must compensate for the added gain with cable loss. When operating at 1 W power output, the sum (in dB) of cable loss and antenna gain shall not exceed 6.0 dB.

100 milliWatt Transmit Power Output or Lower**Table A.6. Monopole antennas** (approved when operating at 100 mW power output or lower.)

Part Number	Type	Connector	Gain	Application
A09-QW	Quarter-wave wire	Permanent	1.9 dBi	Fixed / Mobile
A09-QRAMM	3 " Quarter-wave wire	MMCX	2.1 dBi	Fixed / Mobile
A09-QSM-3	Quarter-wave straight	RPSMA	1.9 dBi	Fixed / Mobile
A09-QSM-3H	Heavy duty quarter-wave straight	RPSMA	1.9 dBi	Fixed / Mobile
A09-QBMM-P6I	Quarter-wave w/ 6" pigtail	MMCX	1.9 dBi	Fixed / Mobile
A09-QHRN	Miniature Helical Right Angle solder	Permanent	-1 dBi	Fixed / Mobile
A09-QHSN	Miniature Helical Right Angle solder	Permanent	-1 dBi	Fixed / Mobile
A09-QHSM-2	2" Straight	RPSMA	1.9 dBi	Fixed / Mobile
A09-QHRSM-2	2" Right angle	RPSMA	1.9 dBi	Fixed / Mobile
A09-QHRSM-170	1.7" Right angle	RPSMA	1.9 dBi	Fixed / Mobile
A09-QRSM-380	3.8" Right angle	RPSMA	1.9 dBi	Fixed / Mobile
A09-QAPM-520	5.2" Articulated Screw mount	Permanent	1.9 dBi	Fixed / Mobile
A09-QSPM-3	3" Straight screw mount	Permanent	1.9 dBi	Fixed / Mobile
A09-QAPM-3	3" Articulated screw mount	Permanent	1.9 dBi	Fixed / Mobile
A09-QAPM-3H	3" Articulated screw mount	Permanent	1.9 dBi	Fixed / Mobile

Table A.7. Yagi antennas (approved when operating at 100 mW power output or lower.)

Part Number	Type	Connector	Gain	Application
A09-Y6	2 Element Yagi	RPN	6.1 dBi	Fixed / Mobile
A09-Y7	3 Element Yagi	RPN	7.1 dBi	Fixed / Mobile
A09-Y8	4 Element Yagi	RPN	8.1 dBi	Fixed / Mobile
A09-Y9	4 Element Yagi	RPN	9.1 dBi	Fixed / Mobile
A09-Y10	5 Element Yagi	RPN	10.1 dBi	Fixed / Mobile
A09-Y11	6 Element Yagi	RPN	11.1 dBi	Fixed / Mobile
A09-Y12	7 Element Yagi	RPN	12.1 dBi	Fixed / Mobile
A09-Y13	9 Element Yagi	RPN	13.1 dBi	Fixed / Mobile
A09-Y14	10 Element Yagi	RPN	14.1 dBi	Fixed / Mobile
A09-Y14	12 Element Yagi	RPN	14.1 dBi	Fixed / Mobile
A09-Y15	13 Element Yagi	RPN	15.1 dBi	Fixed / Mobile
A09-Y15	15 Element Yagi	RPN	15.1 dBi	Fixed / Mobile
A09-Y6TM	2 Element Yagi	RPTNC	6.1 dBi	Fixed / Mobile
A09-Y7TM	3 Element Yagi	RPTNC	7.1 dBi	Fixed / Mobile
A09-Y8TM	4 Element Yagi	RPTNC	8.1 dBi	Fixed / Mobile
A09-Y9TM	4 Element Yagi	RPTNC	9.1 dBi	Fixed / Mobile
A09-Y10TM	5 Element Yagi	RPTNC	10.1 dBi	Fixed / Mobile
A09-Y11TM	6 Element Yagi	RPTNC	11.1 dBi	Fixed / Mobile
A09-Y12TM	7 Element Yagi	RPTNC	12.1 dBi	Fixed / Mobile
A09-Y13TM	9 Element Yagi	RPTNC	13.1 dBi	Fixed / Mobile
A09-Y14TM	10 Element Yagi	RPTNC	14.1 dBi	Fixed / Mobile
A09-Y14TM	12 Element Yagi	RPTNC	14.1 dBi	Fixed / Mobile
A09-Y15TM	13 Element Yagi	RPTNC	15.1 dBi	Fixed / Mobile
A09-Y15TM	15 Element Yagi	RPTNC	15.1 dBi	Fixed / Mobile

IC (Industry Canada) Certification

Labeling requirements for Industry Canada are similar to those of the FCC. A clearly visible label on the outside of the final product enclosure must display the following text:

Contains Model 9XTend Radio, IC: 4214A-9XTEND

Integrator is responsible for its product to comply with IC ICES-003 & FCC Part 15, Sub. B - Unintentional Radiators. ICES-003 is the same as FCC Part 15 Sub. B and Industry Canada accepts FCC test report or CISPR 22 test report for compliance with ICES-003.

Appendix B: Development Guide

XTend Development Kit Contents

The XTend Development Kit includes the hardware and software needed to create long range wireless links.

Table B.1. XTend Development Kit Contents

Item	Qty.	Description	Part Number
Quick Start Guide	1	Familiarizes users with some of the module's most important functions.	MD0016
CD	1	Contains documentation, software and tools needed for RF operation.	MD0010
XTend OEM RF Module	1	Long Range 900 MHz OEM RF Module w/ RPSMA Connector	XT09-SI
XTend OEM RF Module	1	Long Range 900 MHz OEM RF Module w/ attached antenna	XT09-MI
MaxStream Interface Board	2	Enables communication to RS-232/485/422 devices	XTIB-R
Antenna	1	900 MHz RPSMA, 6" Half-Wave, dipole, articulating	A09-HASM-675
Serial Loopback Adapter	1	Connects to the female RS-232 (DB-9) serial connector of the MaxStream Interface Board and can be used to configure the module to function as a repeater (for range testing)	JD2D3-CDL-A
NULL Modem Adapter (male-to-male)	1	Connects to the female RS-232 (DB-9) serial connector of the MaxStream Interface Board and can be used to connect the module to another DCE (female DB9) device	JD2D2-CDN-A
NULL Modem Adapter (female-to-female)	1	Used to bypass radios to verify serial cabling is functioning properly	JD3D3-CDN-A
Male DB-9 to RJ-45 Adapter	1	Facilitates adapting the DB-9 Connector of the MaxStream Interface Board to a CAT5 cable (male DB9 to female RJ45)	JE1D2-CDA-A
Female DB-9 to RJ-45 Adapter	1	Facilitates adapting the DB-9 Connector of the MaxStream Interface Board to a CAT5 cable (female DB9 to female RJ45)	JE1D3-CDA-A
Power Adapter	2	Allows Interface Board to be powered by a 110 Volt AC power supply	JP4P2-9V10-6F
RS-232 Cable (6')	2	Connects interface board to devices having an RS-232 serial port	JD2D3-CDS-6F

Interfacing Hardware

MaxStream has developed proprietary interface boards that facilitate the connection between XTend OEM RF Modules and serial devices. MaxStream has developed an interface board that supports the RS-232/485/422 protocols (MaxStream part number: XTIB-R).

The following section illustrates properties of the MaxStream XTIB-R Interface Board. The MaxStream Interface board provides means for connecting the XTend Module to any node that has an available RS-232 or RS-485/422 connector. Since the module requires signals to enter at TTL voltages, one of the main functions of the interface board is to convert signals between TTL levels (5 VDC) and RS-232 levels.

In the following sections, the XTend Module mounted to the XTIB-R interface board will be referred to as a "Module Assembly"

MaxStream RS-232/485 Interface Board

B.1a. Config (Configuration) Switch

Figure B.1. Front View

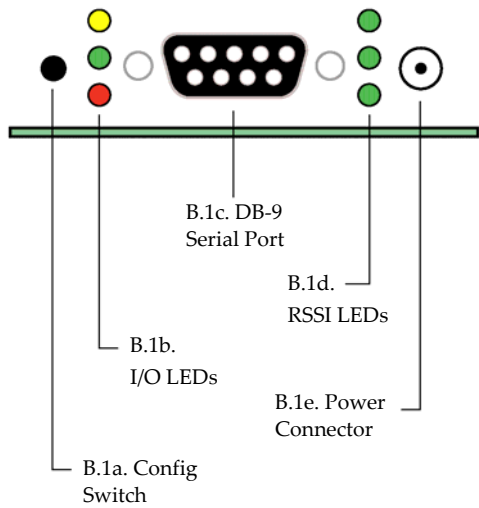

The Configuration Switch provides an alternate method for entering into Command Mode. To enter Command Mode at the modem's default RF data rate, hold the Configuration Switch down for two seconds.

B.1b. I/O LEDs

The I/O LED indicators visualize diagnostic status information. The LEDs indicate module activity as follows:

- Yellow (top LED) = Serial Data Out (to host)
- Green (middle) = Serial Data In (from host)
- Red (bottom) = Power/TX Indicator (Red light is on when powered; it pulses on/off briefly during RF transmission.)



B.1c. DB-9 Serial Port

Standard female DB-9 (RS-232) DCE connector – This connector can be also used for RS-485 and RS-422 connections.

B.1d. RSSI LEDs

RSSI LEDs indicate the amount of fade margin present in an active wireless link. Fade margin is the difference between the incoming signal strength and the module's receiver sensitivity.

- 3 LEDs on = Very Strong Signal (> 30 dB fade margin)
- 2 LEDs on = Strong Signal (> 20 dB fade margin)
- 1 LED on = Moderate Signal (> 10 dB fade margin)
- 0 LED on = Weak Signal (< 10 dB fade margin)

B.1e. Power Connector

7-28 VDC Power Connector (Center positive, 5.5/2.1mm)

Note: The XTIB-R interface board can accept voltages as low as 5V. Contact MaxStream support to enable this option.

B.2a. DIP Switch

Figure B.2. Back View

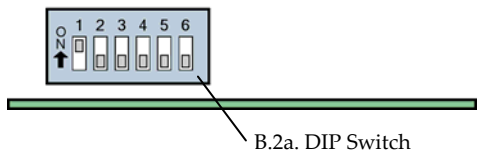

DIP Switch automatically configures the XTend Module to operate in different modes during the power-on sequence. Each time the module assembly (interface board + XTend Module) is powered-on, intelligence on the XTIB-R interface board programs the attached module according to the positions of the DIP Switch. Refer to the figure below for DIP Switch settings.

Figure B.3. MaxStream XTIB-R (RS-232/485) Interface Board DIP Switch Settings

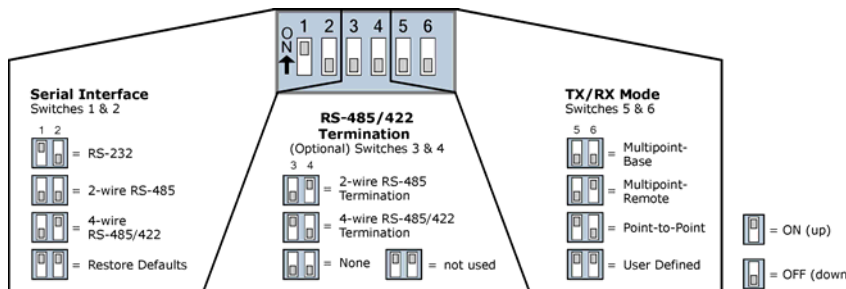

Table B.2. [next page] summaries configurations triggered by the DIP Switch.

Automatic DIP Switch Configurations

Each time an RF Modem is powered on, AT commands are sent to the on-board RF module as dictated by the positions of the DIP switches. DIP switch configurations are sent automatically during the power-on sequence and affect modem parameter values as shown in the table below.

Figure B.4. XTIB-R DIP Switch

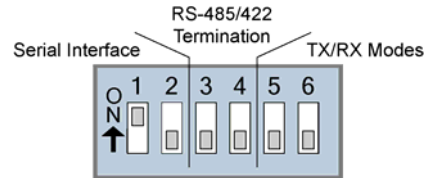

Table B.2. Power-up Options - Commands sent to the module as result of DIP Switch Settings (SW = DIP Switch)

Switches	Condition	Behavior	Commands Sent During Power-up
Switches 1 & 2 (Restore Defaults / Serial Interfacing)	If SW1 & SW2 are ON (up)	Restore Defaults	ATRE (Restore Defaults) ATWR (Write defaults to non-volatile memory)
	If SW1 is ON (up)	RS-232 Operation	ATCS 0 (RS-232, CTS flow control)
	If SW1 is OFF (down)	RS-485/422 Operation	ATCS 3 (RS-485 or RS-422 Operation)
Switches 5 & 6 (TX/RX Modes)	If SW5 & SW6 are OFF (down)	Multipoint Base	ATMY 0 (Source Address) ATDT FFFF (Destination Address) ATMT 3 (Multi-Transmit option)
	If SW5 is OFF (down) & SW6 is ON (up)	Multipoint Remote	ATAM (Auto-set MY, MY = unique) ATDT 0 (Destination Address) ATMT 0 (Multi-Transmit option) ATRR A (Retries)
	If SW5 is ON (up) & SW6 is OFF (down)	Point-to-Point	ATAM (Auto-set MY, MY = unique) ATDT FFFF (Destination Address) ATMT 3 (Multi-Transmit option)
	If SW5 is ON (up) & SW6 is ON (up)	User Defined	Processor is disabled and AT Commands are not sent to the modem (except for CS command as shown below.)

IMPORTANT: To avoid overwriting previously stored custom configurations (due to the automatic configurations that take place each time the RF modem is powered-on), it is necessary to disable a processor located inside the RF modem.

To disable the processor, turn switches 5 and 6 ON (up). When switches 5 and 6 are ON, only the CS command is sent [refer to table below].

Table B.3. User Defined Mode (Switches 5 and 6 are ON (up))

DIP Switches ON (up)	Condition	Command Sent During Power-up
SW1, SW5 and SW6	If CS = 0, 1, 2 or 4	CS parameter remains the same
	If CS = 3	ATCS 0 (RS-232 operation, CTS flow control)
SW2, SW5 and SW6	If CS = 2	ATCS 2 (GPO1 high)
SW5 and SW6 only	If CS = 0, 1, 2, 3 or 4	ATCS 3 (RS-485/422 Operation)

4.4.2. Adapters

The XTend Development Kit comes with several adapters that support the following functions:

- Performing Range Tests
- Testing Cables
- Connecting to other RS-232 DCE and DTE devices
- Connecting to terminal blocks or RJ-45 (for RS-485/422 devices)

NULL Modem Adapter (male-to-male)

Part Number: JD2D2-CDN-A (Black, DB-9 M-M) The male-to-male NULL modem adapter is used to connect two DCE devices. A DCE device connects with a straight-through cable to the male serial port of a computer (DTE).

Figure B.5. Male NULL modem adapter and pinouts

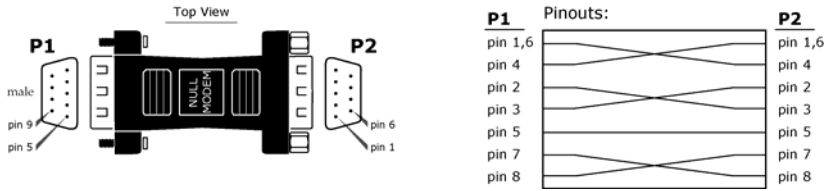
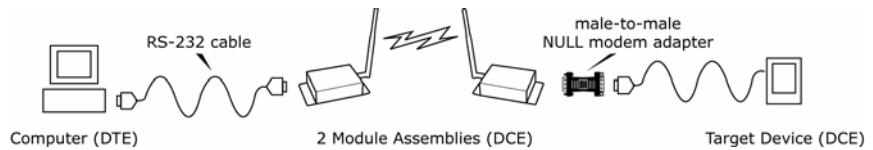

Figure B.6. Example of a MaxStream Radio Modem (DCE Device) connecting to another DCE device



NULL Modem Adapter (female-to-female)

Part Number: JD3D3-CDN-A (Gray, DB-9 F-F) The female-to-female NULL modem adapter is used to verify serial cabling is functioning properly. To test cables, insert the female-to-female NULL modem adapter in place of a pair of module assemblies (XTIB-R-R interface board + XTend Module) and test the connection without radio modules in the connection.

Figure B.7. Female NULL modem adapter and pinouts

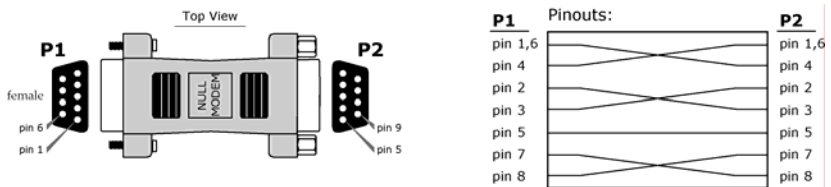

Serial Loopback Adapter

Part Number: JD2D3-CDL-A (Red, DB-9 M-F) The serial loopback adapter is used for range testing. During a range test, the serial loopback adapter configures the module to function as a repeater by looping serial data back into the radio for retransmission.

Figure B.8. Serial loopback adapter and pinouts

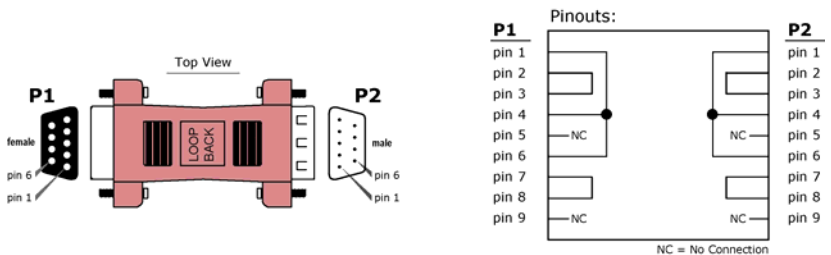

For use in RS-485/422 systems: DB-9 to RJ-45 adapters are documented on p57.

4.4.3. Antennas

[Refer to [Appendix A](#) for a list of FCC-Approved Antennas]

Factors that determine wireless link range:

- Ambient RF noise (interference)
- Line-of-sight obstructions
- Transmit power
- Receive sensitivity
- Antenna configuration

XTend Antenna Connector Options

To comply with the FCC rules and obtain a “modular” certification, it is required that XTend Modules utilize a “non standard” connector. This is to ensure the modules are used only with approved antennas. The XTend Modules have two connector options:

- RPSMA
- MMCX

Alternatively, the XTend Module can be order with an attached wire antenna.

RPSMA

The Reverse Polarity SMA (RPSMA) connector uses the same body as a regular SMA connector. In order to be a “non standard” connector, the gender of the center conductor is changed. The female RPSMA actually has a male center conductor.

MMCX

The Micro-Miniature Connector (MMCX) is a good solution for high volume, price-sensitive applications. The small size and snap on connection make it suitable for attaching an external mounted antenna to a module inside an enclosure.



Antenna Cables

RF cables are typically used to connect a radio installed in a cabinet to an antenna mounted externally. As a general rule, it is best to keep the RF cable as short as possible. All cables promote signal loss which is usually measured in dB loss per 100 ft. MaxStream provides LMR-195 rated cables. Common cables and dB losses are included in this table:

Table B.4. Potential Signal Strength Loss due to Antenna Cable Length

Cable Type	Loss at 900 MHz per 100' (loss per 100m)	Loss at 2.4 GHz per 100' (loss per 100m)	Diameter
RG-58	14.5 dB (47.4 dB)	25.3 dB (83.2 dB)	0.20" (4.95 mm)
RG-174	25.9 dB (85.0 dB)	44.4 dB (145.8 dB)	0.10" (2.54 mm)
RG-316	24.7 dB (81.0 dB)	42.4 dB (139.0 dB)	0.10" (2.59 mm)
LMR-195	11.1 dB (36.5 dB)	19.0 dB (62.4 dB)	0.20" (4.95 mm)
LMR-240	7.6 dB (24.8 dB)	12.9 dB (42.4 dB)	0.24" (6.10 mm)
LMR-600	2.5 dB (8.2 dB)	4.4 dB (14.5 dB)	0.59" (15.0 mm)

Interfacing Protocols

The XTend Module Assembly (XTend OEM RF Module mounted to the XTIB-R Interface Board) supports the following interfacing protocols:

- RS-232
- RS-485 (2-wire) Half-Duplex
- RS-485 (4-wire) and RS-422

RS-232 Operation

DIP Switch Settings and Serial Port Connections

Figure B.9. RS-232 DIP Switch Settings

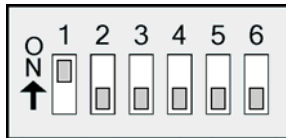

DIP Switch settings are read and applied only while powering-on.

Figure B.10. Pins used on the female RS-232 (DB-9) Serial Connector

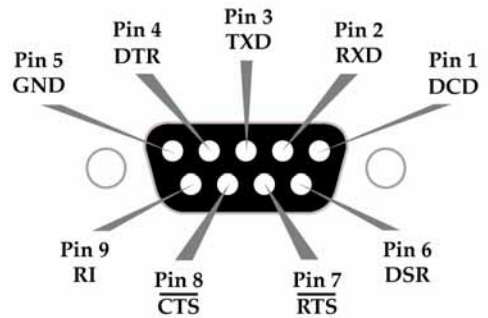

Table B.5. RS-232 Signals and their implementations on the XTend Module Assembly (Low-asserted signals are distinguished by horizontal line over pin name.)

DB-9 Pin	RS-232 Name	X-CTU Name*	Description	Implementation
1	DCD	GPO2	Data-Carrier-Detect	Connected to DSR (pin6)
2	RXD	DO	Received Data	Serial data exiting the Module (to host)
3	TXD	DI	Transmitted Data	Serial data entering into the Module (from host)
4	DTR	GPI2	Data-Terminal-Ready	Can enable POWER-DOWN on the Module
5	GND	-	Ground Signal	Ground
6	DSR	GPO2	Data-Set-Ready	Connected to DCD (pin1)
7	$\overline{\text{RTS}}$ / CMD	GPI1	Request-to-Send	Provides $\overline{\text{RTS}}$ flow control or enables "Command Mode" on the Module
8	$\overline{\text{CTS}}$	GP01	Clear-to-Send	Provides $\overline{\text{CTS}}$ flow control
9	DI	-	Ring Indicator	Optional power input that is connected internally to the positive lead of the front power connector

* X-CTU is software that can be used to configure the Module. The software includes a naming convention where "DI" stands for Data Input and "DO" for Data Output.

Wiring Diagram: RS-232 DTE Device to a DCE Module Assembly

Figure B.11. RS-232 DTE (male connector) device wired to an XTend Module Assembly (female connector)

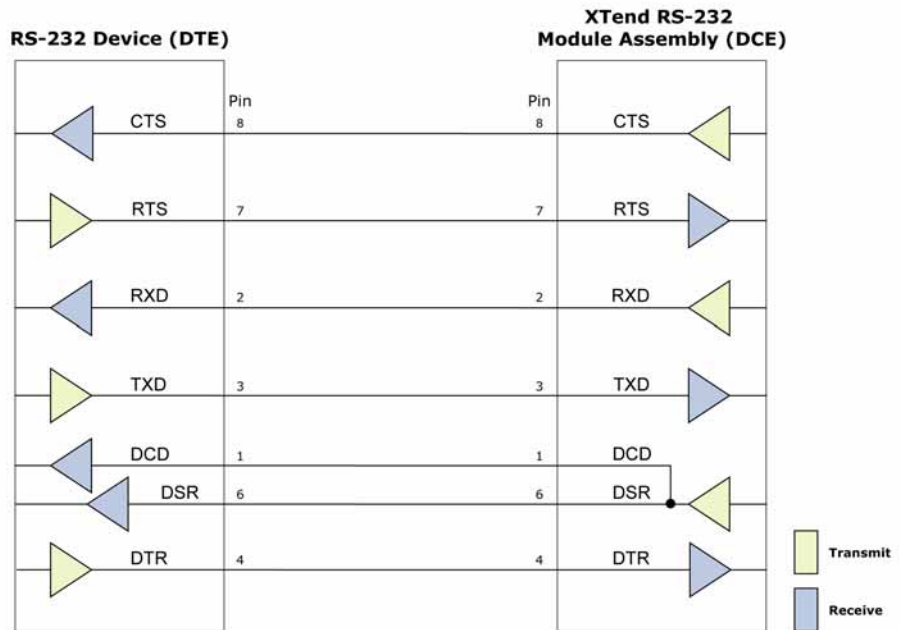

Wiring Diagram: DCE Module Assembly to an RS-232 DCE Device

Figure B.12. XTend Module Assembly (female connector) wired to an RS-232 DTE (male connector) device

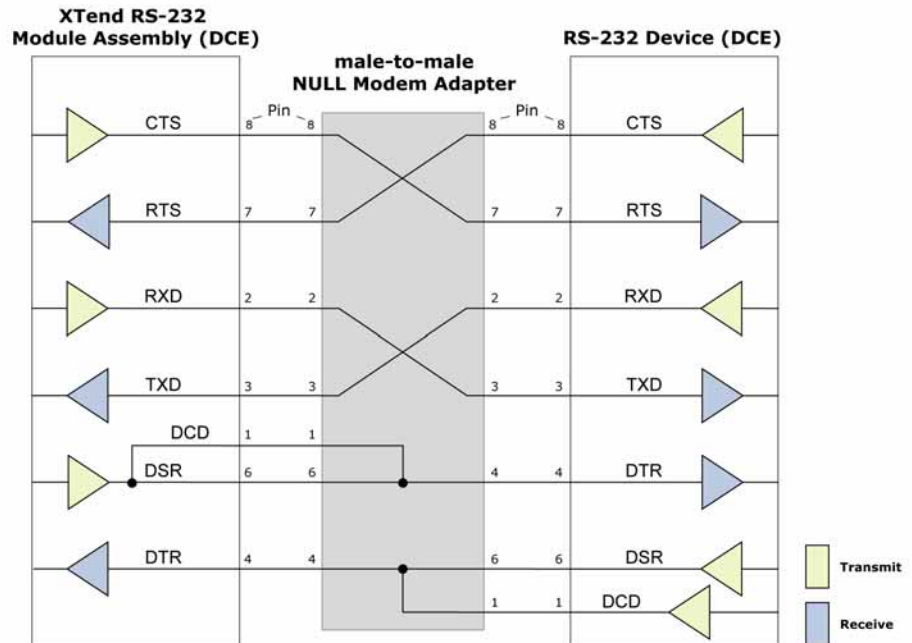

Sample Wireless Connection: DTE ⇄ DCE ⚡ DCE ⇄ DCE

Figure B.13. Typical wireless connection used for serial communications between DTE and DCE devices

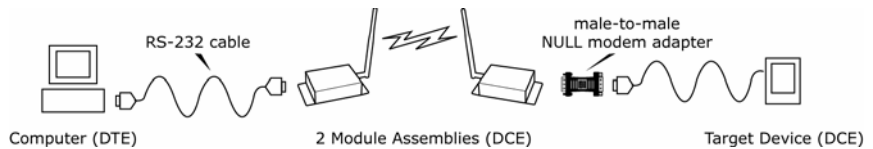

RS-485 (2-wire) Operation

DIP Switch Settings and Serial Port Connections

Figure B.14.
RS-485 (2-wire) Half-Duplex
DIP Switch Settings

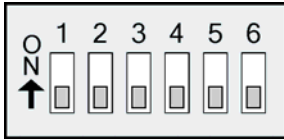
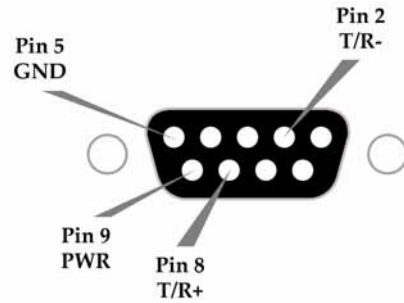

Figure B.16.
RS-485 (2-wire) with Termination (optional)



Figure B.15.
Pins used on the female RS-232 (DB-9)
Serial Connector



Termination is the 120 Ω resistor between T+ and T-.

DIP Switch settings are read and applied only while powering-on.

Note: Refer to Figures B.22 and B.23 for RJ-45 connector pin designations used in RS-485/422 environments.

Table B.6. RS-485 (2-wire half-duplex) Signals and their implementations on the XTend Module Assembly

DB-9 Pin	RS-485 Name	Description	Implementation
2	T/R- (TRA)	Negative Data Line	Transmit serial data to and from the XTend Module Assembly
5	GND	Ground Signal	Ground
8	T/R+ (TRB)	Positive Data Line	Transmit serial data to and from the XTend Module Assembly
9	PWR	Power	Optional power input that is connected internally to the front power connector
1, 3, 4, 6, 7			not used

Wiring Diagram: RS-485 (2-wire) Half-Duplex

Figure B.17. XTend Module Assembly in an RS-485 (2-wire) half-duplex environment

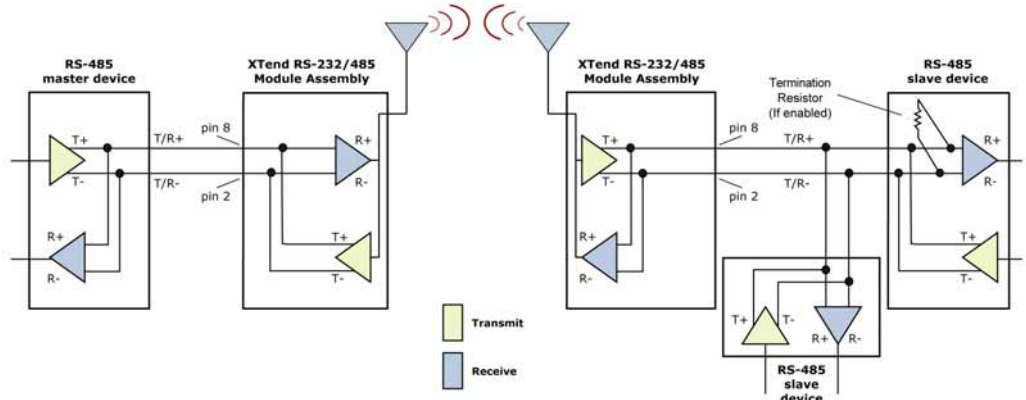

RS-485 (4-wire) & RS-422 Operation

DIP Switch Settings and Serial Port Connections

Figure B.18.
RS-485 (4-wire) and RS-422
DIP Switch Settings

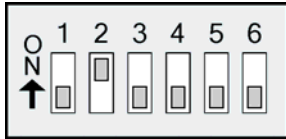

Figure B.20.
RS-485 (4-wire) & RS-422 with Termination (optional)



Termination is the 120 Ω resistor between T+ and T-.

DIP Switch settings are read and applied only while powering-on.

Figure B.19.
Pins used on the female RS-232 (DB-9)
Serial Connector

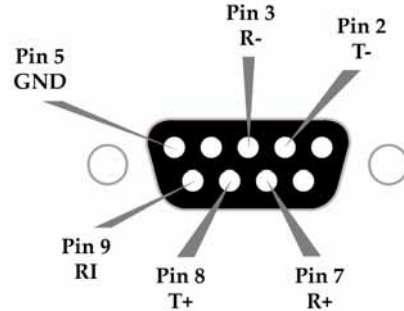
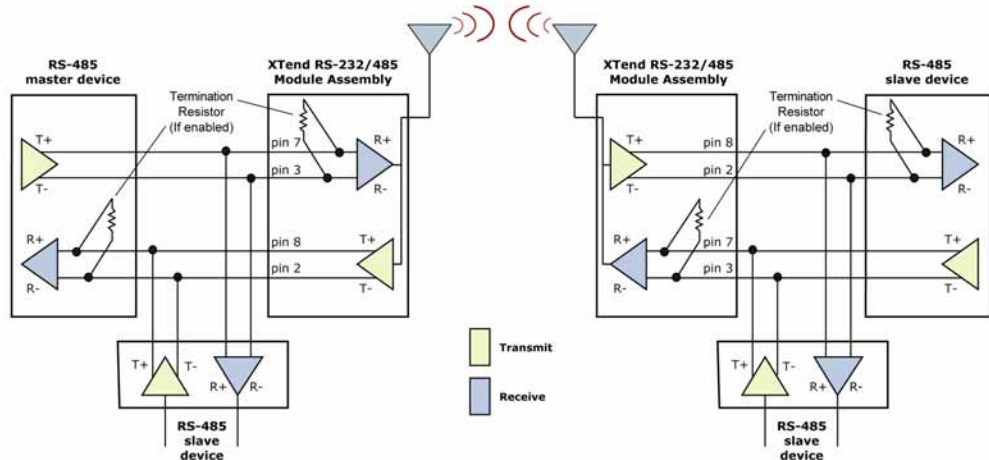

Table B.7. RS-485/422 (4-wire) Signals and their implementations with the XTend-PKG-R Module Assembly

DB-9 Pin	RS-485/422 Name	Description	Implementation
2	T- (TA)	Transmit Negative Data Line	Serial data sent from the XTend Module Assembly
3	R- (RA)	Receive Negative Data Line	Serial data received by the XTend Module Assembly
5	GND	Signal Ground	Ground
7	R+ (RB)	Receive Positive Data Line	Serial data received by the XTend Module Assembly
8	T+ (TB)	Transmit Positive Data Line	Serial data sent from the XTend Module Assembly
9	PWR	Power	Optional power input that is connected internally to the front power connector
1, 4, 6			not used

Wiring Diagram: RS-485 (4-wire) Half-Duplex

Figure B.21. XTend Module Assembly in an RS-485 (4-wire) environment



Wiring Diagram: RS-422

Figure B.22. XTend Module Assembly in an RS-485 (4-wire) environment

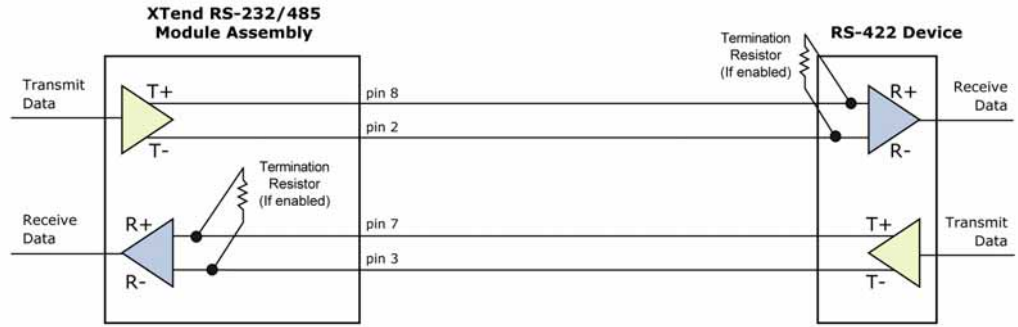

RS-485/422 Connection Guidelines

The RS-485/422 protocol provides a solution for wired communications that can tolerate high noise and push signals over long cable lengths. RS-485/422 signals can communicate as far as 4000 feet (1200 m). RS-232 signals are suitable for cable distances up to 100 feet (30.5 m).

RS-485 offers multi-drop capability in which up to 32 nodes can be connected. The RS-422 protocol is used for point-to-point communications.

Suggestions for integrating the XTend Modem with the RS-485/422 protocol:

1. When using Ethernet twisted pair cabling: Select wires so that T+ and T- are connected to each wire in a twisted pair. Likewise, select wires so that R+ and R- are connected to a twisted pair. (For example, tie the green and white/green wires to T+ and T-.)
2. For straight-through Ethernet cable (not cross-over cable) – The following wiring pattern works well: Pin3 to T+, Pin4 to R+, Pin5 to R-, Pin6 to T-
3. Note that the connecting cable only requires 4 wires (even though there are 8 wires).
4. When using phone cabling (RJ-11) – Pin2 in the cable maps to Pin3 on opposite end of cable and Pin1 maps to Pin4 respectively.

Figure B.23. Male (yellow) DB-9 to RJ-45 Adapters

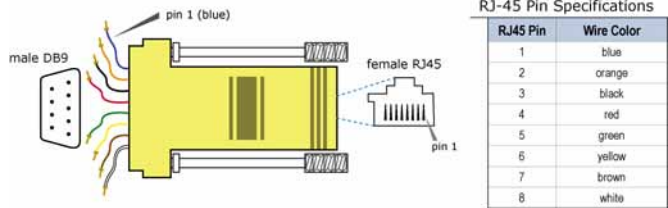
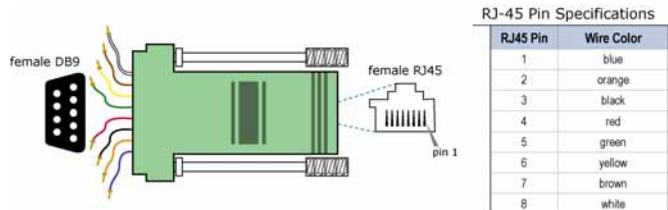

Figure B.24. Female (green) DB-9 to RJ-45 Adapters



X-CTU Software

Using the X-CTU Software

X-CTU is MaxStream-provided software used to interface with and configure XTend OEM RF Modules. The software application is organized into the following four tabs:

- PC Settings tab - Setup PC serial ports to interface with an XTend Module assembly
- Range Test tab – Test XTend Module's range and monitor packets sent and received
- Terminal tab – Set and read XTend Module parameters using AT Commands
- Modem Configuration tab – Set and read XTend Module parameters

Figure B.25. X-CTU User Interface (PC Settings, Range Test, Terminal and Modem Configuration tabs)

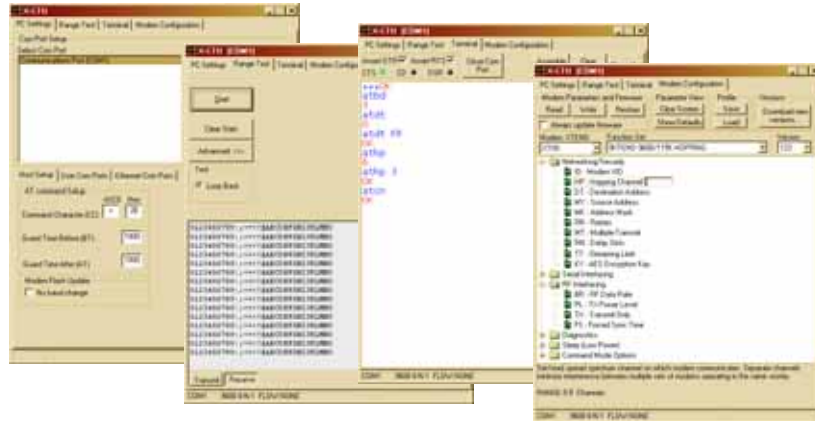

Install X-CTU software

Double-click the "setup_X-CTU.exe" file and follow prompts of the installation screens. This file is located in the 'software' folder of the MaxStream CD and also under the 'Downloads' section of the following web page: <http://www.maxstream.net/helpdesk/download.php>

Setup

To use the X-CTU software, a module assembly (XTend Module mounted to a MaxStream XTIB-R-R Interface Board) must be connected to the serial port of a PC. The data rate and parity settings of the serial port ("PC Settings" tab) must match those of the module (BD (Baud Rate) and NB (Parity) Commands).

Serial Communications Software

A terminal program is built into the X-CTU Software. Other terminal programs such as "HyperTerminal" can also be used. When issuing AT Commands through a terminal program interface, use the following syntax:

Figure B.26. Syntax for sending AT Commands:

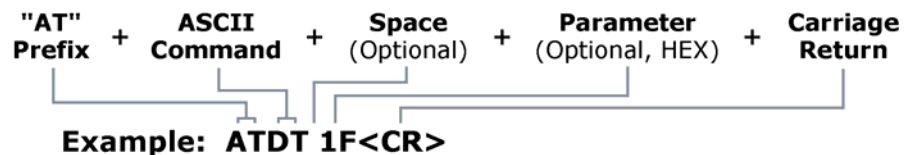

NOTE: To read a parameter value stored in a register, leave the parameter field blank.

The example above issues DT Command to change destination address of the module to "0x1F". To save the new value to the module's non-volatile (long term) memory, issue WR (Write) Command after modifying parameters.

Appendix C: Additional Information

1-Year Warranty

XTend OEM RF Modules from MaxStream, Inc. (the "Product") are warranted against defects in materials and workmanship under normal use, for a period of 1-year from the date of purchase. In the event of a product failure due to materials or workmanship, MaxStream will repair or replace the defective product. For warranty service, return the defective product to MaxStream, shipping prepaid, for prompt repair or replacement.

The foregoing sets forth the full extent of MaxStream's warranties regarding the Product. Repair or replacement at MaxStream's option is the exclusive remedy. THIS WARRANTY IS GIVEN IN LIEU OF ALL OTHER WARRANTIES, EXPRESS OR IMPLIED, AND MAXSTREAM SPECIFICALLY DISCLAIMS ALL WARRANTIES OF MERCHANTABILITY OR FITNESS FOR A PARTICULAR PURPOSE. IN NO EVENT SHALL MAXSTREAM, ITS SUPPLIERS OR LICENSORS BE LIABLE FOR DAMAGES IN EXCESS OF THE PURCHASE PRICE OF THE PRODUCT, FOR ANY LOSS OF USE, LOSS OF TIME, INCONVENIENCE, COMMERCIAL LOSS, LOST PROFITS OR SAVINGS, OR OTHER INCIDENTAL, SPECIAL OR CONSEQUENTIAL DAMAGES ARISING OUT OF THE USE OR INABILITY TO USE THE PRODUCT, TO THE FULL EXTENT SUCH MAY BE DISCLAIMED BY LAW. SOME STATES DO NOT ALLOW THE EXCLUSION OR LIMITATION OF INCIDENTAL OR CONSEQUENTIAL DAMAGES. THEREFOR, THE FOREGOING EXCLUSIONS MAY NOT APPLY IN ALL CASES. This warranty provides specific legal rights. Other rights which vary from state to state may also apply.

Ordering Information

Figure C.1 MaxStream OEM RF Module Part Numbers Key

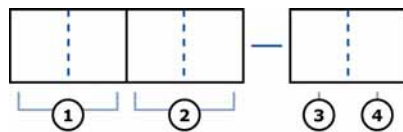

Divisions of the MaxStream OEM RF Module Part Number:

- | | |
|--|---|
| <p>① MaxStream Product Family
XT = XTend</p> <p>② Operating Frequency
09 = 902-928 MHz</p> | <p>③ Antenna Connector
M = MMCX
S = RPSMA (Reverse Polarity SMA)</p> <p>④ Temperature Rating
I = Industrial (-40 to 85° C, conformal coated)
T = Tested (-40 to 85° C, conformal coated, 100% tested)</p> |
|--|---|

For example:

XT09-SI = 9XTend OEM RF Module, 900 MHz, RPSMA Antenna, Industrial Temperature Rating

Contact MaxStream

Free and unlimited technical support is included with every MaxStream Radio Modem sold.
Please use the following resources for additional support:

Documentation:	http://www.maxstream.net/helpdesk/download.php
Technical Support:	Phone. (866) 765-9885 toll-free U.S. & Canada (801) 765-9885 Worldwide
	Live Chat. www.maxstream.net
	E-Mail. rf-xperts@maxstream.net

MaxStream office hours are 8:00 am – 5:00 pm [U.S. Mountain Standard Time]